

**METHOD 8A - DETERMINATION OF SULFURIC ACID VAPOR  
OR MIST AND SULFUR DIOXIDE EMISSIONS FROM  
KRAFT RECOVERY FURNACES**

**NCASI  
Southern Regional Center  
December 1996**

## **Acknowledgments**

This method was prepared by Ashok K. Jain, Regional Manager at the NCASI Southern Regional Center.

### **For more information about this method, contact:**

Ashok K. Jain  
NCASI  
P. O. Box 141020  
Gainesville, FL 32614-1020  
(352) 377-4708, ext. 226  
FAX (352) 371-6557

### **For information about NCASI publications, contact:**

Publications Coordinator  
NCASI  
P. O. Box 13318  
Research Triangle Park, NC 27709-3318  
(919) 558-1987

National Council of the Paper Industry for Air and Stream Improvement, Inc. (NCASI). 1997. *Methods Manual, Method 8 - Determination of Sulfuric Acid Vapor or Mist and Sulfur Dioxide Emissions from Kraft Recovery Furnaces*, Research Triangle Park, N.C.: National Council of the Paper Industry for Air and Stream Improvement, Inc.

© 1997 by the National Council of the Paper Industry for Air and Stream Improvement, Inc.

### ***NCASI's Mission***

*To serve the forest products industry as a center of excellence for providing technical information and scientific research needed to achieve the industry's environmental goals.*

## **Disclaimer**

The mention of trade names or commercial products does not constitute endorsement or recommendation for use.

# METHOD 8A - DETERMINATION OF SULFURIC ACID VAPOR OR MIST AND SULFUR DIOXIDE EMISSIONS FROM KRAFT RECOVERY FURNACES

## 1.0 Introduction

This method was developed as an alternative to EPA Method 8 for determining sulfuric acid emissions from kraft recovery furnaces. When testing recovery furnaces, EPA Method 8 is subject to significant interference from sulfates, which are present in the particulate matter, and sulfur dioxide. The alternative method uses a quartz in-line filter to remove particulate matter from the gas stream prior to capturing sulfuric acid. The use of a controlled condensation technique eliminates the potential for interference from sulfur dioxide.

EPA approved the use of Method 8A in December 1996 for the determination of acid vapor or mist and sulfur dioxide emissions from kraft recovery furnaces.

## 2.0 Method Description

### 2.1 Principle and applicability

**2.1.1 Principle** - A gas sample is extracted from the sampling point in the recovery furnace stack. The sulfuric acid vapor or mist (including sulfur trioxide) and the sulfur dioxide are separated, and both fractions are measured separately by the barium-thorin titration method.

**2.1.2 Applicability** - This method is applicable for the determination of sulfuric acid vapor or mist (including sulfur trioxide, and in the presence of other particulate matter) and sulfur dioxide emissions from kraft recovery furnaces. Tests have shown the minimum detectable limits of the method are 0.50 milligrams/cubic meter ( $3.1 \times 10^{-8}$  lb/ft<sup>3</sup>) for sulfur trioxide. No upper limits have been established. Based on theoretical calculations, for 200 mL of 3% hydrogen peroxide solution, the upper concentration limit for sulfur dioxide in a 1.0 m<sup>3</sup> (35.3 ft<sup>3</sup>) gas sample is about 12,500 mg/m<sup>3</sup> ( $7.7 \times 10^{-4}$  lb/ft<sup>3</sup>). The upper limit can be extended by increasing the quantity of peroxide solution in the impingers.

Possible interfering agents of this method are fluorides, free ammonia, dimethyl aniline and recovery furnace salt cake.

### 2.2 Apparatus

**2.2.1 Sampling** - A schematic of the sampling train used in this method is shown in Figure 1. Component parts are discussed below. The schematic is similar to the EPA Method 6 (see Appendix A) train except that the impingers are not the midget type but larger as in the EPA Method 8 (see Appendix C) train. Also, the

impingers are preceded by a heated sampling probe, a heated quartz filter holder and a heated H<sub>2</sub>SO<sub>4</sub> condenser.

**2.2.1.1 Probe** - Quartz, straight tube approximately 12-mm inside diameter, with a heating element and a stainless steel jacket. A thermocouple taped on the quartz tube and insulated with glass wool allows for measurement of the probe temperature.

**2.2.1.2 Sulfuric acid sampling box** - Insulated box with heating elements for filter holder and H<sub>2</sub>SO<sub>4</sub> condenser.

(a) **Filter holder** - Quartz, as described in Figure 2. Filter medium is Tissuquartz filter paper with a 37-mm diameter (Pallflex Corporation). Filter holder is always maintained at temperatures >260°C (500°F) by a cylindrical heating mantle.

(b) **H<sub>2</sub>SO<sub>4</sub> condenser** - Modified Graham condenser, with Type C glass frit and 200 cm of 5-mm ID glass tubing for condenser coil, as shown in Figure 3. Condenser filled with water and temperature maintained between 75 and 85°C (167 to 185°F) with a cylindrical heating mantle.

**2.2.1.3 Thermocouples** - Copper-constantan thermocouples to measure temperatures at the probe end, after the filter holder and after the H<sub>2</sub>SO<sub>4</sub> condenser (see Figure 1).

**2.2.1.4 Impingers** - Three, as shown in Figure 1. The first and third impingers shall be of the Greenburg-Smith design with standard tips. The second shall be of the Greenburg-Smith design, modified by replacing the insert with an approximately 13 mm (0.5 in.) ID glass tube, having an unstricted tip located 13 mm (0.5 in.) from the bottom of the flask.

**2.2.1.5 Metering system** - Same as EPA Method 6, Sections 2.1.5 to 2.1.10, except rotameter should be capable of measuring flow rate to within 2% of the selected flow rate of about 10,000 cc/min (and not 1,000 cc/min).

**2.2.1.6 Barometer** - Same as EPA Method 6, Section 2.1.11.

**2.2.1.7 Vacuum gauge and rotameter** - Same as EPA Method 6, Section 2.1.12.

**2.2.2 Sample Recovery** - Same as EPA Method 8, Section 2.2.

**2.2.3 Analysis** - Same as EPA Method 8, Section 2.3.

## 2.3 Reagents

### 2.3.1 Sampling

**2.3.1.1 Filters** - Tissuequartz filter papers with a 37-mm diameter (Pallflex Corporation).

**2.3.1.2 Silica Gel, Water, Hydrogen Peroxide, Crushed Ice** - Same as described in EPA Method 8, Section 3.1.3 to 3.1.6.

**2.3.2 Sample Recovery** - Water. Same as for EPA Method 8, Section 3.2.

### 2.3.3 Analysis

**2.3.3.1 Water, thiorin indicator, barium perchlorate and sulfuric acid standard** - Same as for EPA Method 8, Section 3.3.

## 2.4 Procedure

### 2.4.1 Sampling

**2.4.1.1 Preparation of collection train** - Measure 100 mL of 3% hydrogen peroxide into each of the first two impingers. Pour 100 mL of distilled deionized water into the third impinger. Retain a portion of each reagent used as a blank solution. Assemble the train as shown in Figure 1. Adjust probe heater to maintain probe temperature above 177°C (350°F) to prevent condensation of H<sub>2</sub>SO<sub>4</sub> in the gas passing through the probe. Adjust heaters to the quartz filter and sulfuric acid condenser to the desired temperatures given in Sections 2.2.1.2 (a) and 2.2.1.2 (b). Place crushed ice around the impingers.

**2.4.1.2 Leak-check procedure** - Follow the procedure laid out in EPA Method 8, Section 4.1.4.

**2.4.1.3 Sample collection** - Record the initial dry gas meter reading and barometric pressure (see data sheet, Figure 4). To begin sampling, position the tip of the probe at the sampling point at right angles to direction of gas flow, connect the probe, filter and condenser assembly to the first impinger, and start the pump. Adjust the sample flow to a constant rate of about 10.0 L/min as indicated by the rotameter. Maintain this constant rate ( $\pm 10\%$ ) during the entire sampling run. Sample for a minimum of 30 minutes and take readings (dry gas meter, temperatures at dry gas meter, probe, filter and condenser) at least every five minutes (Figure 4). Add more ice during the run if needed. At the conclusion of each run, turn off the pump, remove probe from the stack, and record the final readings. Conduct a leak check as

described in Section 2.4.1.2. (This leak check is mandatory.) If the post-leakage rate exceeds the specified acceptable rate (see Section 4.1.4 of EPA Method 8), the tester shall either correct the sample volume, as specified in Section 6.3 of EPA Method 5 (see Appendix B), or shall void the run.

Drain the ice bath and, with the probe disconnected, purge the remaining part of the train by drawing clean ambient air through the system for 15 minutes at the average flow rate used for sampling (see Section 4.1.5 of EPA Method 8 for details).

**2.4.2 Sample recovery** - Disconnect the impingers after purging. Rinse separately the probe, quartz filter holder and the H<sub>2</sub>SO<sub>4</sub> condenser with deionized water using multiple rinses for good washing. Collect the condenser wash solution in Container No. 1, and the No. 1 and No. 2 impinger solutions in Container No. 2. Note levels of liquids in each container.

**2.4.3 Sample analysis** - Note the level of liquid in containers 1 and 2, and confirm whether or not any sample was lost during shipment; note this on the analytical data sheet. If a noticeable amount of leakage has occurred, either void the sample or use methods, subject to the approval of the administrator, to correct the final results.

**2.4.3.1 Container no. 1** - Transfer the entire contents of Container no. 1 into a 250 mL Erlenmeyer flask, add enough isopropyl alcohol to give an 80% isopropyl alcohol solution. Pipette a 100-mL aliquot of this solution into a 250-mL Erlenmeyer flask, add 2 to 4 drops of thiorin indicator, and titrate to a pink end point using 0.0100 N barium perchlorate. Repeat the titration with a second aliquot of sample and average the titration values. Replicate titrations must agree within 1% or 0.2 mL, whichever is greater. Caution: The H<sub>2</sub>SO<sub>4</sub> concentrations in kraft recovery furnace stacks are typically so low that at times almost the entire sample in Container no. 1 may have to be used during the titration.

**2.4.3.2 Container no. 2** - If concurrent SO<sub>2</sub> concentrations in the stack are desired carry out the following. Thoroughly mix the solution in Container no. 2 which holds the contents of the 1st and 2nd impingers. Pipette a 10-mL aliquot of this solution into a 250-mL Erlenmeyer flask. Add 40 mL isopropanol, 2 to 4 drops of thiorin indicator, and titrate to a pink end point using 0.0100 N barium perchlorate. Repeat the titration with a second aliquot of sample and average the titration values. Replicate titrations must agree within 1% or 0.2 mL, whichever is greater.

**2.4.3.3 Blanks** - Prepare blanks by adding 2 to 4 drops of thorin indicator to 100 mL of 80% isopropanol. Titrate the blanks in the same manner as the samples.

**2.5 Calibration** - Same as Section 5 of EPA Method 8.

**2.6 Calculations** - Same as Section 6 of EPA Method 8, except that equation 8-1 should be replaced by equation 6-1 of EPA Method 6, and references to isokinetic sampling in this section should be omitted. Recovery furnace stack gas temperatures are expected to be higher than the estimated dewpoint of H<sub>2</sub>SO<sub>4</sub> in the stack gas, and H<sub>2</sub>SO<sub>4</sub> is expected to be present in vapor phase only. Consequently, neither isokinetic sampling nor a stack traverse is required.

**2.7 Alternative procedures** - Not applicable to this method.

**2.8 References**

National Council of the Paper Industry for Air and Stream Improvement, Inc. (NCASI). 1980. *A study of SO<sub>x</sub> measurement procedures and their use at kraft recovery furnaces*. Atmospheric Quality Improvement Technical Bulletin No. 106. Research Triangle Park, NC: National Council of the Paper Industry for Air and Stream Improvement, Inc.



2.9 Tables, diagrams, flowcharts, and validation data

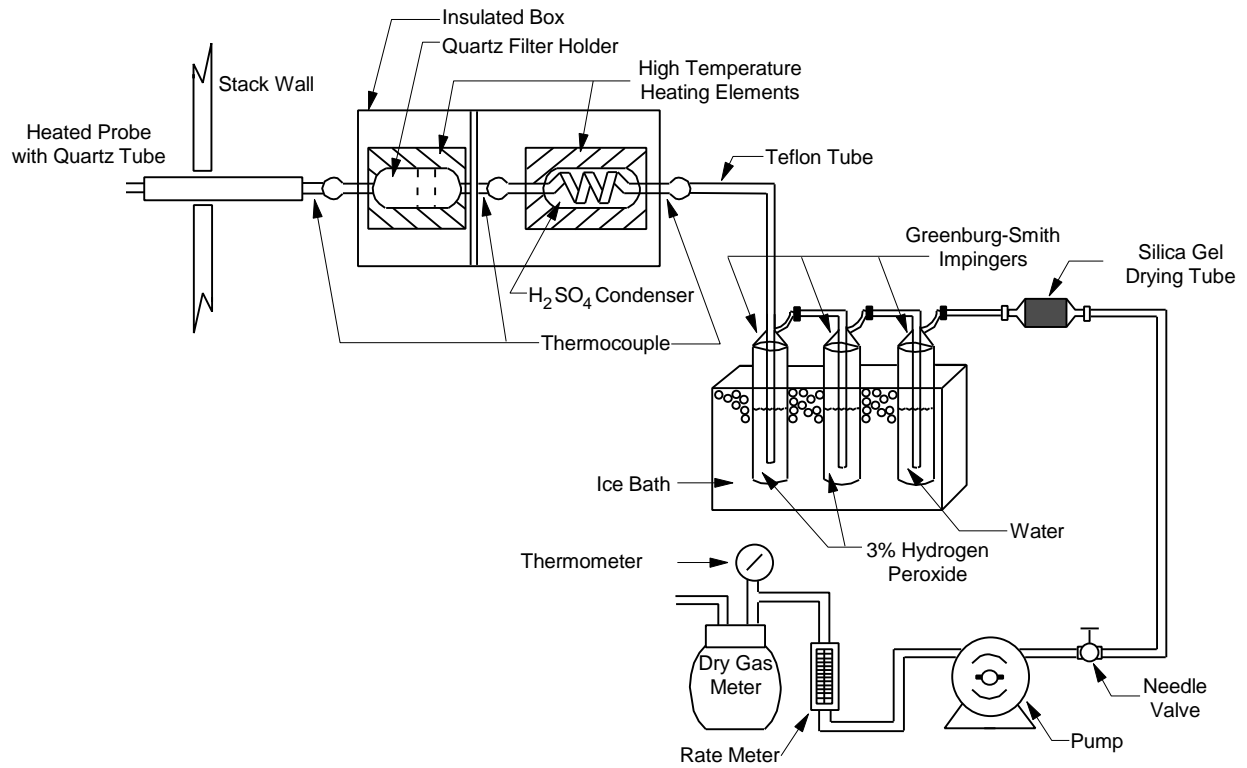

Figure 1. SO<sub>x</sub> Sampling Train

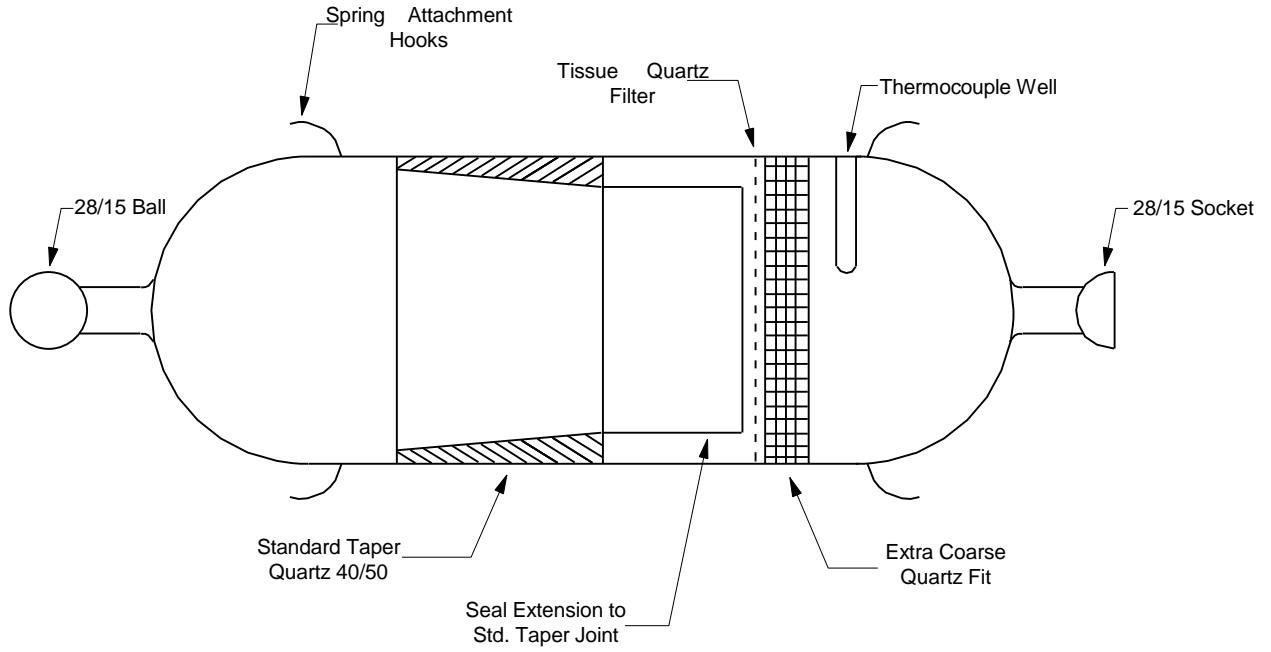

Figure 2. Quartz Filter Holder

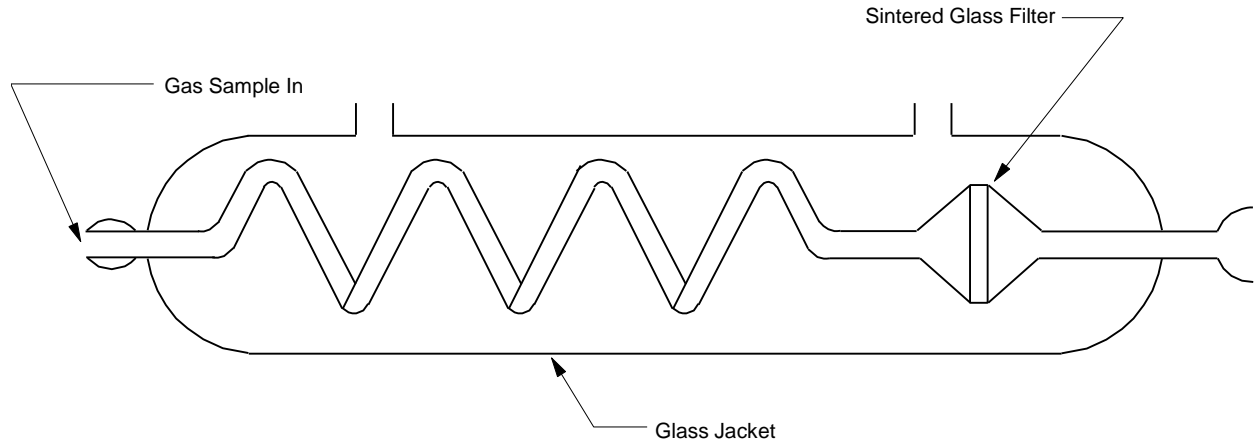

Figure 3. H<sub>2</sub>SO<sub>4</sub> Condenser

Source \_\_\_\_\_

Date \_\_\_\_\_

Run No. \_\_\_\_\_

Furnace Load \_\_\_\_\_

Stack Gas Temp. \_\_\_\_\_

Atmospheric Pressure \_\_\_\_\_

Final Dry Gas Meter Reading \_\_\_\_\_

Initial Dry Gas Meter Reading \_\_\_\_\_

Volume Sampled \_\_\_\_\_

Time (min)	Temperature, °F				
	Probe	Filter	Condenser	Dry Gas Meter	
				In	Out
0					
5					
10					
15					
20					
25					
30					

Figure 4. SO<sub>3</sub> Measurement Field Data Sheet



UNITED STATES ENVIRONMENTAL PROTECTION AGENCY  
RESEARCH TRIANGLE PARK, NC 27711

DEC 2 1996

OFFICE OF  
AIR QUALITY PLANNING  
AND STANDARDS

Mr. Ashok Jain  
NCASI  
Southern Regional Center  
P.O. Box 141020  
Gainesville, Florida 32604

Dear Mr. Jain:

We have reviewed your Technical Bulletin 106 describing your study of sulfur oxide measurement procedures from Kraft recovery furnaces. Although you performed your evaluation before Method 301 existed, we believe that it demonstrates that your proposed test method for sulfuric acid from Kraft recovery furnaces is acceptable. If Method 301 had existed when you were evaluating candidate procedures, it would have required that you compare your candidate procedure to Method 8. However, as your evaluation shows, Method 8 has a potentially significant positive bias when used to measure sulfuric acid emissions from Kraft recovery furnaces. Thus, you could not compare your candidate method directly to Method 8. The alternative that you chose was to investigate as thoroughly as possible whether your candidate method could recover known amounts of sulfuric acid in the presence of the interferences typically found in a stack sample. We believe that your evaluation convincingly demonstrates that your candidate method can accurately measure sulfuric acid emissions from Kraft recovery furnaces. We have concluded that this method, which you identified as Method 8A, should be used instead of Method 8 when measuring sulfuric acid from Kraft recovery furnaces.

We are currently trying to file electronically as many of our documents as possible. Could you please send us an electronic file of Method 8A? The preferred format would be Word Perfect, Version 5.1 or 6.1, but any format would be acceptable.

Sincerely,

A handwritten signature in black ink, appearing to read "William F. Hunt, Jr.", written in a cursive style.

William F. Hunt, Jr.  
Emissions, Monitoring, and  
Analysis Division

cc: Joe Taylor, Georgia Pacific  
Mike Harley, Florida Department of  
Environmental Protection

Figure 5. EPA Approval Letter

**APPENDIX A**

**METHOD 6 - DETERMINATION OF SULFUR DIOXIDE  
EMISSIONS FROM STATIONARY SOURCES**

---

**EMISSION MEASUREMENT TECHNICAL INFORMATION CENTER  
NSPS TEST METHOD**

---

**Method 6 - Determination of Sulfur Dioxide Emissions  
from Stationary Sources**

**1. PRINCIPLE AND APPLICABILITY**

**1.1 Principle.** A gas sample is extracted from the sampling point in the stack. The sulfuric acid mist (including sulfur trioxide) and the sulfur dioxide (SO<sub>2</sub>) are separated. The SO<sub>2</sub> fraction is measured by the barium-thorin titration method.

**1.2 Applicability.**

**1.2.1** This method is applicable for the determination of SO<sub>2</sub> emissions from stationary sources. The minimum detectable limit of the method has been determined to be 3.4 mg of SO<sub>2</sub>/m<sup>3</sup> (2.12 x 10<sup>-7</sup> lb/ft<sup>3</sup>). Although no upper limit has been established, tests have shown that concentrations as high as 80,000 mg/m<sup>3</sup> of SO<sub>2</sub> can be collected efficiently in two midget impingers, each containing 15 ml of 3 percent hydrogen peroxide, at a rate of 1.0 liter/min for 20 minutes. Based on theoretical calculations, the upper concentration limit in a 20-liter sample is about 93,300 mg/m<sup>3</sup>.

**1.2.2** Possible interferants are free ammonia, water-soluble cations, and fluorides. The cations and fluorides are removed by glass wool filters and an isopropanol bubbler, and hence do not affect the SO<sub>2</sub> analysis. When samples are being taken from a gas stream with high concentrations of very fine metallic fumes (such as found in inlets to control devices), a high-efficiency glass fiber filter must be used in place of the glass wool plug (i.e., the one in the probe) to remove the cation interferants.

**1.2.3** Free ammonia interferes by reacting with SO<sub>2</sub> to form particulate sulfite and by reacting with the indicator. If free ammonia is present (this can be determined by knowledge of the process and noticing white particulate matter in the probe and isopropanol bubbler), alternative methods, subject to the approval of the Administrator, U.S. Environmental Protection Agency, are required.

**2. APPARATUS**

**2.1 Sampling.**

**2.1.1** The sampling train is shown in Figure 6-1, and component parts are discussed below. The tester has the option of substituting sampling equipment described in Method 8 in place of the midget impinger equipment of Method 6. However, the Method 8 train must be modified to include a heated filter between the probe and isopropanol impinger, and the operation of the sampling train and sample analysis must be at the flow rates and solution volumes defined in Method 8.

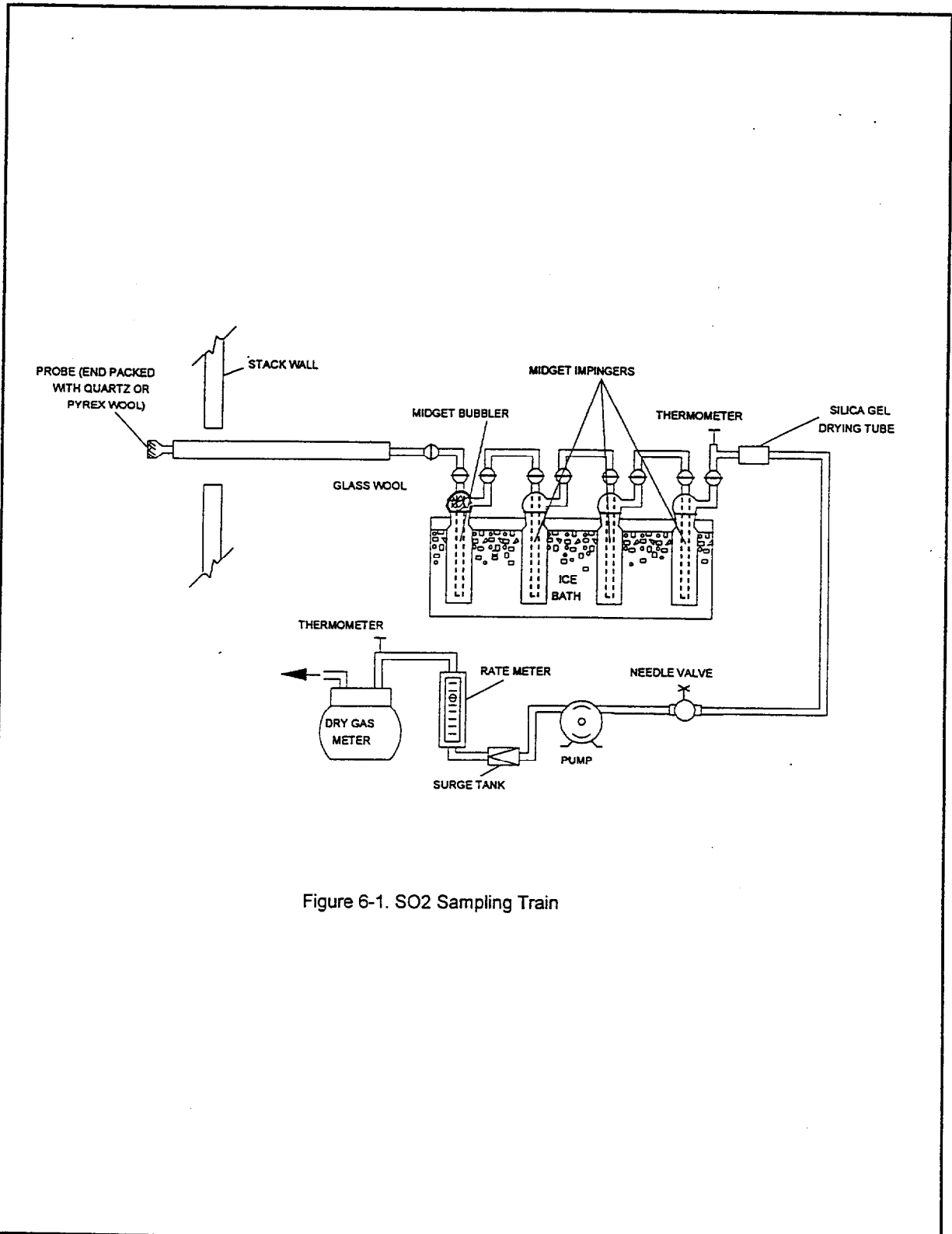

Figure 6-1. SO2 Sampling Train



**2.1.2** The tester also has the option of determining  $\text{SO}_2$  simultaneously with particulate matter and moisture determinations by (1) replacing the water in a Method 5 impinger system with 3 percent peroxide solution, or (2) by replacing the Method 5 water impinger system with a Method 8 isopropanol-filter-peroxide system. The analysis for  $\text{SO}_2$  must be consistent with the procedure of Method 8.

**2.1.1 Probe.** Borosilicate glass, or stainless steel (other materials of construction may be used, subject to the approval of the Administrator), approximately 6-mm inside diameter, with a heating system to prevent water condensation and a filter (either in-stack or heated out-stack) to remove particulate matter, including sulfuric acid mist. A plug of glass wool is a satisfactory filter.

**2.1.2 Bubbler and Impingers.** One midget bubbler, with medium-coarse glass frit and borosilicate or quartz glass wool packed in top (see Figure 6-1) to prevent sulfuric acid mist carryover, and three 30-ml midget impingers. The bubbler and midget impingers must be connected in series with leak-free glass connectors. Silicone grease may be used, if necessary, to prevent leakage.

**2.1.2.1** At the option of the tester, a midget impinger may be used in place of the midget bubbler.

**2.1.2.2** Other collection absorbers and flow rates may be used, subject to the approval of the Administrator, but the collection efficiency must be shown to be at least 99 percent for each test run and must be documented in the report.

If the efficiency is found to be acceptable after a series of three tests, further documentation is not required. To conduct the efficiency test, an extra absorber must be added and analyzed separately. This extra absorber must not contain more than 1 percent of the total  $\text{SO}_2$ .

**2.1.3 Glass Wool.** Borosilicate or quartz.

**2.1.4 Stopcock Grease.** Acetone-insoluble, heat-stable silicone grease may be used, if necessary.

**2.1.5 Temperature Gauge.** Dial thermometer, or equivalent, to measure temperature of gas leaving impinger train to within  $1^\circ\text{C}$  ( $2^\circ\text{F}$ ).

**2.1.6 Drying Tube.** Tube packed with 6- to 16-mesh indicating-type silica gel, or equivalent, to dry the gas sample and to protect the meter and pump. See also the note in Method 5, Section 3.1.2.

**2.1.7 Valve.** Needle valve, to regulate sample gas flow rate.

**2.1.8 Pump.** Leak-free diaphragm pump, or equivalent, to pull gas through the train. Install a small surge tank between the pump and rate meter to eliminate the pulsation effect of the diaphragm pump on the rotameter.

**2.1.9 Rate Meter.** Rotameter, or equivalent, capable of measuring flow rate to within 2 percent of the selected flow rate of about 1000 cc/min.

**2.1.10 Volume Meter.** Dry gas meter (DGM), sufficiently accurate to measure the sample volume to within 2 percent, calibrated at the selected flow rate and conditions actually encountered during sampling, and equipped with a temperature gauge (dial thermometer, or equivalent) capable of measuring temperature accurately to within  $3^\circ\text{C}$  ( $5.4^\circ\text{F}$ ).

**2.1.11 Barometer.** Mercury, aneroid, or other barometer capable of measuring atmospheric pressure to within 2.5 mm (0.1 in.) Hg. See the note in Method 5, Section 2.1.9.

**2.1.12 Vacuum Gauge and Rotameter.** At least 760-mm (30-in.) Hg gauge and 0 to 40-cc/min rotameter, to be used for leak-check of the sampling train.

## **2.2 Sample Recovery.**

**2.2.1 Wash Bottles.** Polyethylene or glass, 500-ml, two.

**2.2.2 Storage Bottles.** Polyethylene, 100-ml, to store impinger samples (one per sample).

## **2.3 Analysis.**

**2.3.1 Pipettes.** Volumetric type, 5-ml, 20-ml (one per sample), and 25-ml sizes.

**2.3.2 Volumetric Flasks.** 100-ml size (one per sample) and 1000-ml size.

**2.3.3 Burettes.** 5- and 50-ml sizes.

**2.3.4 Erlenmeyer Flasks.** 250-ml size (one for each sample, blank, and standard).

**2.3.5 Dropping Bottle.** 125-ml size, to add indicator.

**2.3.6 Graduated Cylinder.** 100-ml size.

**2.3.7 Spectrophotometer.** To measure absorbance at 352 nanometers.

## **3. REAGENTS**

Unless otherwise indicated, all reagents must conform to the specifications established by the Committee on Analytical Reagents of the American Chemical Society. Where such specifications are not available, use the best available grade.

### **3.1 Sampling.**

**3.1.1 Water.** Deionized distilled to conform to ASTM Specification D 119377, Type 3. At the option of the analyst, the  $\text{KMnO}_4$  test for oxidizable organic

matter may be omitted when high concentrations of organic matter are not expected to be present.

**3.1.2 Isopropanol, 80 Percent.** Mix 80 ml of isopropanol with 20 ml of water.

**3.1.2.1** Check each lot of isopropanol for peroxide impurities as follows: Shake 10 ml of isopropanol with 10 ml of freshly prepared 10 percent potassium iodide solution. Prepare a blank by similarly treating 10 ml of water. After 1 minute, read the absorbance at 352 nanometers on a spectrophotometer, using a 1-cm path length. If absorbance exceeds 0.1, reject alcohol for use.

**3.1.2.2** Peroxides may be removed from isopropanol by redistilling or by passage through a column of activated alumina; however, reagent grade isopropanol with suitably low peroxide levels may be obtained from commercial

sources. Rejection of contaminated lots may, therefore, be a more efficient procedure.

**3.1.3 Hydrogen Peroxide, 3 Percent.** Dilute 30 percent hydrogen peroxide 1:9 (v/v) with water (30 ml is needed per sample). Prepare fresh daily.

**3.1.4 Potassium Iodide Solution, 10 Percent.** Dissolve 10.0 g of KI in water, and dilute to 100 ml. Prepare when needed.

### **3.2 Sample Recovery.**

**3.2.1 Water.** Same as in Section 3.1.1.

**3.2.2 Isopropanol, 80 Percent.** Same as in Section 3.1.2.

### **3.3 Analysis.**

**3.3.1 Water.** Same as in Section 3.1.1.

**3.3.2 Isopropanol, 100 Percent.**

**3.3.3 Thorin Indicator.** 1-(o-arsenophenylazo)-2-naphthol-3,6-disulfonic acid, disodium salt, or equivalent. Dissolve 0.20 g in 100 ml of water.

**3.3.4 Barium Standard Solution, 0.0100 N.** Dissolve 1.95 g of barium perchlorate trihydrate  $[\text{Ba}(\text{ClO}_4)_2 \cdot 3\text{H}_2\text{O}]$  in 200 ml water, and dilute to 1 liter with isopropanol. Alternatively, 1.22 g of barium chloride dihydrate  $[\text{BaCl}_2 \cdot 2\text{H}_2\text{O}]$  may be used instead of the perchlorate. Standardize as in Section 5.5.

**3.3.5 Sulfuric Acid Standard, 0.0100 N.** Purchase or standardize to  $\pm 0.0002$  N against 0.0100 N NaOH which has previously been standardized against potassium acid phthalate (primary standard grade).

**3.3.6 Quality Assurance Audit Samples.** Sulfate samples in glass vials prepared by EPA's Atmospheric Research and Exposure Assessment Laboratory, Quality Assurance Division, Source Branch, Mail Drop 77A, Research Triangle Park, North Carolina 27711. Each set will consist of two vials having solutions of unknown concentrations. Only when making compliance determinations, obtain an audit

sample set from the Quality Assurance Management Office at each EPA regional office or the responsible enforcement agency. (Note: The tester should notify the quality assurance office or the responsible enforcement agency at least 30 days prior to the test date to allow sufficient time for sample delivery.)

## **4. PROCEDURE**

### **4.1 Sampling.**

**4.1.1 Preparation of Collection Train.** Measure 15 ml of 80 percent isopropanol into the midget bubbler and 15 ml of 3 percent hydrogen peroxide into each of the first two midget impingers. Leave the final midget impinger dry. Assemble the train as shown in Figure 6-1. Adjust probe heater to a temperature sufficient to prevent water condensation. Place crushed ice and water around the impingers.

**4.1.2 Leak-Check Procedure.** A leak-check prior to the sampling run is optional; however, a leak-check after the sampling run is mandatory. The leak-check procedure is as follows:

**4.1.2.1** Temporarily attach a suitable (e.g., 0- to 40-cc/min) rotameter to the outlet of the DGM, and place a vacuum gauge at or near the probe inlet. Plug the probe inlet, pull a vacuum of at least 250 mm (10 in.) Hg, and note the flow rate as indicated by the rotameter. A leakage rate not in excess of 2 percent of the average sampling rate is acceptable. Note: Carefully release the probe inlet plug before turning off the pump.

**4.1.2.2** It is suggested (not mandatory) that the pump be leak-checked separately, either prior to or after the sampling run. If done prior to the sampling run, the pump leak-check shall precede the leak-check of the sampling train described immediately above; if done after the sampling run, the pump leak-check shall follow the train leak-check. To leak-check the pump, proceed as follows: Disconnect the drying tube from the probe-impinger assembly. Place a vacuum gauge at the inlet to either the drying tube or the pump, pull a vacuum of 250 mm (10 in.) Hg, plug or pinch off the outlet of the flow meter, and then turn off the pump. The vacuum should remain stable for at least 30 seconds.

**4.1.2.3** Other leak-check procedures may be used, subject to the approval of the Administrator, U.S. Environmental Protection Agency.

#### **4.1.3 Sample Collection.**

**4.1.3.1** Record the initial DGM reading and barometric pressure. To begin sampling, position the tip of the probe at the sampling point, connect the probe to the bubbler, and start the pump. Adjust the sample flow to a constant rate of approximately 1.0 liter/min as indicated by the rotameter. Maintain this constant rate ( $\pm 10$  percent) during the entire sampling run. Take readings (DGM, temperatures at DGM and at impinger outlet, and rate meter) at least every 5 minutes. Add more ice during the run to keep the temperature of the gases leaving the last impinger at 20°C (68°F) or less. At the conclusion of each run, turn off the pump, remove probe from the stack, and record the final readings.

Conduct a leak-check as in Section 4.1.2. (This leak-check is mandatory.) If a leak is found, void the test run or use procedures acceptable to the Administrator to adjust the sample volume for the leakage. Drain the ice bath, and purge the remaining part of the train by drawing clean ambient air through the system for 15 minutes at the sampling rate.

**4.1.3.2** Clean ambient air can be provided by passing air through a charcoal filter or through an extra midget impinger with 15 ml of 3 percent H<sub>2</sub>O<sub>2</sub>. The tester may opt to use simply ambient air without purification.

**4.2 Sample Recovery.** Disconnect the impingers after purging. Discard the contents of the midget bubbler. Pour the contents of the midget impingers into a leak-free polyethylene bottle for shipment. Rinse the three midget impingers and the connecting tubes with water, and add the washings to the same storage container. Mark the fluid level. Seal and identify the sample container.

### 4.3 Sample Analysis.

4.3.1 Note level of liquid in container, and confirm whether any sample was lost during shipment; note this on analytical data sheet. If a noticeable amount of leakage has occurred, either void the sample or use methods, subject to the approval of the Administrator, to correct the final results.

4.3.2 Transfer the contents of the storage container to a 100-ml volumetric flask, and dilute to exactly 100 ml with water. Pipette a 20-ml aliquot of this solution into a 250-ml Erlenmeyer flask, add 80 ml of 100 percent isopropanol and two to four drops of thorin indicator, and titrate to a pink endpoint using 0.0100 N barium standard solution. Repeat, and average the titration volumes. Run a blank with each series of samples. Replicate titrations must agree within 1 percent or 0.2 ml, whichever is larger.

4.3.3 Note: Protect the 0.0100 N barium standard solution from evaporation at all times.

### 4.4 Audit Sample Analysis.

4.4.1 Concurrently analyze the two audit samples and a set of compliance samples (Section 4.3) in the same manner to evaluate the technique of the analyst and the standards preparation. (Note: It is recommended that known quality control samples be analyzed prior to the compliance and audit sample analysis to optimize the system accuracy and precision. One source of these samples is the Source Branch listed in Section 3.3.6.) The same analysts, analytical reagents, and analytical system shall be used both for compliance samples and the EPA audit samples; if this condition is met, auditing of subsequent compliance analyses for the same enforcement agency within 30 days is not required. An audit sample set may not be used to validate different sets of compliance samples under the jurisdiction of different enforcement agencies, unless prior arrangements are made with both enforcement agencies.

4.4.2 Calculate the concentrations in mg/dscm using the specified sample volume in the audit instructions. (Note: Indication of acceptable results may be obtained immediately by reporting the audit results in mg/dscm and compliance results in total mg SO<sub>2</sub>/sample by telephone to the responsible enforcement agency.) Include the results of both audit samples, their identification numbers, and the analyst's name with the results of the compliance determination samples in appropriate reports to the EPA regional office or the appropriate enforcement agency. Include this information with subsequent compliance analyses for the same enforcement agency during the 30-day period.

4.4.3 The concentrations of the audit samples obtained by the analyst shall agree within 5 percent of the actual concentrations. If the 5-percent specification is not met, reanalyze the compliance samples and audit samples, and include initial and reanalysis values in the test report (see Note in first paragraph of this section).

4.4.4 Failure to meet the 5-percent specification may require retests until the audit problems are resolved. However, if the audit results do not affect the compliance or noncompliance status of the affected facility, the Administrator may waive the reanalysis requirement, further audits, or retests and accept the results of the compliance test. While steps are being taken to resolve audit analysis problems, the Administrator may also choose to use the data to determine the compliance or noncompliance status of the affected facility.

## 5. CALIBRATION

### 5.1 Metering System.

#### 5.1.1 Initial Calibration.

5.1.1.1 Before its initial use in the field, first leak-check the metering system (drying tube, needle valve, pump, rotameter, and DGM) as follows: Place a vacuum gauge at the inlet to the drying tube, and pull a vacuum of 250 mm (10 in.) Hg; plug or pinch off the outlet of the flow meter, and then turn off the pump. The vacuum shall remain stable for at least 30 seconds. Carefully release the vacuum gauge before releasing the flow meter end.

5.1.1.2 Next, remove the drying tube, and calibrate the metering system (at the sampling flow rate specified by the method) as follows: Connect an appropriately sized wet test meter (e.g., 1 liter per revolution) to the inlet of the drying tube. Make three independent calibration runs, using at least five revolutions of the DGM per run. Calculate the calibration factor, Y (wet test meter calibration volume divided by the DGM volume, both volumes adjusted to the same reference temperature and pressure), for each run, and average the results. If any Y-value deviates by more than 2 percent from the average, the metering system is unacceptable for use. Otherwise, use the average as the calibration factor for subsequent test runs.

5.1.2 **Post-Test Calibration Check.** After each field test series, conduct a calibration check as in Section 5.1.1 above, except for the following variations: (a) the leak-check is not to be conducted, (b) three, or more revolutions of the DGM may be used, and (c) only two independent runs need be made. If the calibration factor does not deviate by more than 5 percent from the initial calibration factor (determined in Section 5.1.1), then the DGM volumes obtained during the test series are acceptable. If the calibration factor deviates by more than 5 percent, recalibrate the metering system as in Section 5.1.1, and for the calculations, use the calibration factor (initial or recalibration) that yields the lower gas volume for each test run.

5.2 **Thermometers.** Calibrate against mercury-in-glass thermometers.

5.3 **Rotameter.** The rotameter need not be calibrated, but should be cleaned and maintained according to the manufacturer's instruction.

5.4 **Barometer.** Calibrate against a mercury barometer.

5.5 **Barium Standard Solution.** Standardize the barium perchlorate or chloride solution against 25 ml of standard sulfuric acid to which 100 ml of 100 percent isopropanol has been added. Run duplicate analyses. Calculate the normality using the average of a pair of duplicate analyses where the titrations agree within 1 percent or 0.2 ml, whichever is larger.

## 6. CALCULATIONS

Carry out calculations, retaining at least one extra decimal figure beyond that of the acquired data. Round off figures after final calculation.

### 6.1 Nomenclature.

$C_{SO_2}$  = Concentration of  $SO_2$ , dry basis corrected to standard conditions,  $mg/dsm^3$  (lb/dscf).

- $N$  = Normality of barium standard titrant, meq./ml.  
 $P_{\text{bar}}$  = Barometric pressure at the exit orifice of the DGM, mm Hg (in. Hg).  
 $P_{\text{std}}$  = Standard absolute pressure, 760 mm Hg (29.92 in. Hg).  
 $T_m$  = Average DGM absolute temperature, °K (°R).  
 $T_{\text{std}}$  = Standard absolute temperature, 293°K (528°R).  
 $V_a$  = Volume of sample aliquot titrated, ml.  
 $V_m$  = Dry gas volume as measured by the DGM, dcm (dcf).  
 $V_{m(\text{std})}$  = Dry gas volume measured by the DGM, corrected to standard conditions, dscm (dscf).  
 $V_{\text{soln}}$  = Total volume of solution in which the  $\text{SO}_2$  sample is contained, 100 ml.  
 $V_t$  = Volume of barium standard titrant used for the sample (average of replicate titrations), ml.  
 $V_{\text{tb}}$  = Volume of barium standard titrant used for the blank, ml.  
 $Y$  = DGM calibration factor.  
 32.03 = Equivalent weight of  $\text{SO}_2$ .

### 6.2 Dry Sample Gas Volume, Corrected to Standard Conditions.

$$V_{m(\text{std})} = V_m Y \left( \frac{T_{\text{std}}}{T_m} \right) \left( \frac{P_{\text{bar}}}{P_{\text{std}}} \right) = K_1 Y V_m \frac{P_{\text{bar}}}{T_m} \quad \text{Eq. 6-1}$$

Where:

- $K_1 = 0.3858 \text{ } ^\circ\text{K}/\text{mm Hg}$  for metric units,  
 $= 17.64 \text{ } ^\circ\text{R}/\text{in. Hg}$  for English units.

### 6.3 $\text{SO}_2$ Concentration.

$$C_{\text{SO}_2} = K_2 \frac{(V_t - V_{\text{tb}}) N \left( \frac{V_{\text{soln}}}{V_a} \right)}{V_{m(\text{std})}} \quad \text{Eq. 6-2}$$

$K_2 = 32.03 \text{ mg/meq. for metric units,}$   
 $= 7.061 \times 10^{-5} \text{ lb/meq. for English units.}$

#### 6.4 Relative Error (RE) for QA Audit Samples, Percent.

$$RE = \frac{C_d - C_a}{C_a} (100) \quad \text{Eq. 6-3}$$

$C_d$  = Determined audit sample concentration, mg/dscm.

$C_a$  = Actual audit sample concentration, mg/dscm.

### 7. ALTERNATIVE PROCEDURES

**7.1 DGM as a Calibration Standard.** A DGM may be used as a calibration standard for volume measurements in place of the wet test meter specified in Section 5.1, provided that it is calibrated initially and recalibrated periodically according to the same procedures outlined in Method 5, Section 7.1, with the following exceptions: (1) the DGM is calibrated against a wet test meter having a capacity of 1 liter/rev or 3 liters/rev and having the capability of measuring volume to within 1 percent; (2) the DGM is calibrated at 1 liter/min (2 cfh); and (3) the meter box of the Method 6 sampling train is calibrated at the same flow rate.

**7.2 Critical Orifices for Volume and Rate Measurements.** A critical orifice may be used in place of the DGM specified in Section 2.1.10, provided that it is selected, calibrated, and used as follows:

**7.2.1 Preparation of Collection Train.** Prepare the sampling train as shown in Figure 6-2. The rotameter and surge tank are optional but are recommended in order to detect changes in the flow rate. (Note: The critical orifices can be adapted to a Method 6 type sampling train as follows: Insert sleeve type, serum bottle stoppers into two reducing unions. Insert the needle into the stoppers as shown in Figure 6-3.)

#### 7.2.2 Selection of Critical Orifices.

**7.2.2.1** The procedure that follows describes the use of hypodermic needles and stainless steel needle tubings, which have been found suitable for use as critical orifices. Other materials and critical orifice designs may be used provided the orifices act as true critical orifices, i.e., a critical vacuum can be obtained, as described in this section. Select a critical orifice that is sized to operate at the desired flow rate. The needle sizes and tubing lengths shown below give the following approximate flow rates.



Gauge/cm	Flow rate, cc/min	Gauge/cm	Flow rate, cc/min
21/7.6	1100	23/3.8	500
22/2.9	1000	23/5.1	450
22/3.8	900	24/3.2	400

7.2.2.2 Determine the suitability and the appropriate operating vacuum of the critical orifice as follows: If applicable, temporarily attach a rotameter and surge tank to the outlet of the sampling train. Turn on the pump, and adjust the valve to give an outlet vacuum reading corresponding to about half of the atmospheric pressure. Observe the rotameter reading. Slowly increase the vacuum until a stable reading is obtained on the rotameter. Record the critical vacuum, which is the outlet vacuum when the rotameter first reaches a stable value. Orifices that do not reach a critical value shall not be used.

### 7.2.3 Field Procedure.

7.2.3.1 **Leak-Check Procedure.** A leak-check before the sampling run is recommended, but is optional. The leak-check procedure is as follows: Temporarily attach a suitable (e.g., 0-40 cc/min) rotameter and surge tank, or a soap bubble meter and surge tank to the outlet of the pump. Plug the probe inlet, pull an outlet vacuum of at least 254 mm Hg (10 in. Hg), and note the flow rate as indicated by the rotameter or bubble meter. A leakage rate not in excess of 2 percent of the average sampling rate ( $Q_{std(avg)}$ ) is acceptable. Carefully release the probe inlet plug before turning off the pump.

7.2.3.2 **Moisture Determination.** At the sampling location, prior to testing, determine the percent moisture of the ambient air using the wet and dry bulb temperatures or, if appropriate, a relative-humidity meter.

7.2.3.3 **Critical Orifice Calibration.** Prior to testing, at the sampling location, calibrate the entire sampling train using a 500-cc soap bubble meter which is attached to the inlet of the probe and an outlet vacuum of 25 to 50 mm Hg (1 to 2 in. Hg) above the critical vacuum. Record the information listed in Figure 6-4. Calculate the standard volume of air measured by the soap bubble meter and the volumetric flow rate using the equations below:

$$V_{sb(std)} = V_{sb} \left( \frac{T_{std}}{T_{amb}} \right) \left( \frac{P_{bar}}{P_{std}} \right) \quad \text{Eq. 6-4}$$

$$Q_{std} = \frac{V_{sb(std)}}{\theta} \quad \text{Eq. 6-5}$$

Where:

$P_{bar}$  = Barometric pressure, mm Hg (in. Hg).

$P_{std}$  = Standard absolute pressure, 760 mm Hg (29.92 in. Hg).

$Q_{std}$  = Volumetric flow rate through critical orifice, scm/min (scf/min).

$T_{amb}$  = Ambient absolute temperature of air, °K (°R).

$T_{std}$  = Standard absolute temperature, 273°K (528°R).

$V_{sb}$  = Volume of gas as measured by the soap bubble meter, m<sup>3</sup> (ft<sup>3</sup>).

$V_{sb(std)}$  = Volume of gas as measured by the soap bubble meter, corrected to standard conditions, scm (scf).

$\theta$  = Time, min.

#### 7.2.3.4 Sampling.

7.2.3.4.1 Operate the sampling train for sample collection at the same vacuum used during the calibration run. Start the watch and pump simultaneously. Take readings (temperature, rate meter, inlet vacuum, and outlet vacuum) at least every 5 minutes. At the end of the sampling run, stop the watch and pump simultaneously.

7.2.3.4.2 Conduct a post-test calibration run using the calibration procedure outlined in Section 7.2.3.3. If the  $Q_{std}$  obtained before and after the test differ by more than 5 percent, void the test run; if not, calculate the volume of the gas measured with the critical orifice,  $V_{m(std)}$ , using Equation 6-6 and the average of  $Q_{std}$  of both runs, as follows:

$$V_{m(std)} = \bar{Q}_{std} \theta_s (1 - B_{wa}) \left( \frac{P_{bar} + P_{sr}}{P_{bar} + P_c} \right) \quad \text{Eq. 6-6}$$

Where:

$V_{m(std)}$  = Dry gas volume measured with the critical orifice, corrected to standard conditions, dscm (dscf).

$Q_{std(avg)}$  = Average flow rate of pretest and post-test calibration runs, scm/min (scf/min).

$B_{wa}$  = Water vapor in ambient air, proportion by volume.

$\theta_s$  = Sampling time, min.

$P_c$  = Inlet vacuum reading obtained during the calibration run, mm Hg (in. Hg).

$P_{sr}$  = Inlet vacuum reading obtained during the sampling run, mm Hg (in. Hg).

7.2.3.4.3 If the percent difference between the molecular weight of the ambient air at saturated conditions and the sample gas is more than ±3 percent, then the molecular weight of the gas sample must be considered in the calculations using the following equation:

$$V_{m(\text{std})} = \bar{Q}_{\text{std}} \theta_s (1-B_{wa}) \sqrt{\frac{M_a}{M_s}} \left( \frac{P_{\text{bar}} + P_{\text{sr}}}{P_{\text{bar}} + P_c} \right) \quad \text{Eq. 6-7}$$

Where:

$M_a$  = Molecular weight of the ambient air saturated at impinger temperature, g/g-mole (lb/lb-mole).

$M_s$  = Molecular weight of the sample gas saturated at impinger temperature, g/g-mole (lb/lb-mole).

**7.2.3.4.4 Note:** A post-test leak-check is not necessary because the post-test calibration run results will indicate whether there is any leakage.

**7.2.3.4.5** Drain the ice bath, and purge the sampling train using the procedure described in Section 4.1.3.

#### BIBLIOGRAPHY

1. Atmospheric Emissions from Sulfuric Acid Manufacturing Processes. U.S. DHEW, PHS, Division of Air Pollution. Public Health Service Publication No. 999-AP-13. Cincinnati, OH. 1965.
2. Corbett, P.F. The Determination of  $\text{SO}_2$  and  $\text{SO}_3$  in Flue Gases. Journal of the Institute of Fuel. 24:237-243. 1961.
3. Matty, R.E. and E.K. Diehl. Measuring Flue-Gas  $\text{SO}_2$  and  $\text{SO}_3$ . Power. 101:9497. November 1957.
4. Patton, W.F. and J.A. Brink, Jr. New Equipment and Techniques for Sampling Chemical Process Gases. J. Air Pollution Control Association. 13:162. 1963.
5. Rom, J.J. Maintenance, Calibration, and Operation of Isokinetic Source-Sampling Equipment. Office of Air Programs, Environmental Protection Agency. Research Triangle Park, NC. APTD-0576. March 1972.
6. Hamil, H.F. and D.E. Camann. Collaborative Study of Method for the Determination of Sulfur Dioxide Emissions from Stationary Sources (Fossil-Fuel Fired Steam Generators). Environmental Protection Agency, Research Triangle Park, NC. EPA-650/4-74-024. December 1973.
7. Annual Book of ASTM Standards. Part 31; Water, Atmospheric Analysis. American Society for Testing and Materials. Philadelphia, PA. 1974. pp. 40-42.
8. Knoll, J.E. and M.R. Midgett. The Application of EPA Method 6 to High Sulfur Dioxide Concentrations. Environmental Protection Agency. Research Triangle Park, NC. EPA-600/4-76-038. July 1976.
9. Westlin, P. R. and R. T. Shigehara. Procedure for Calibrating and Using Dry Gas Volume Meters as Calibration Standards. Source Evaluation Society Newsletter. 3(1):17-30. February 1978.
10. Yu, K. K. Evaluation of Moisture Effect on Dry Gas Meter Calibration. Source Evaluation Society Newsletter. 5(1):24-28. February 1980.

11. Lodge, J.P., Jr., J.B. Pate, B.E. Ammons, and G.A. Swanson. The Use of Hypodermic Needles as Critical Orifices in Air Sampling. J. Air Pollution Control Association. 16:197-200. 1966.
12. Shigehara, R.T., and Candace B. Sorrell. Using Critical Orifices as Method 5 Calibration Standards. Source Evaluation Society Newsletter. 10:4-15. August 1985.

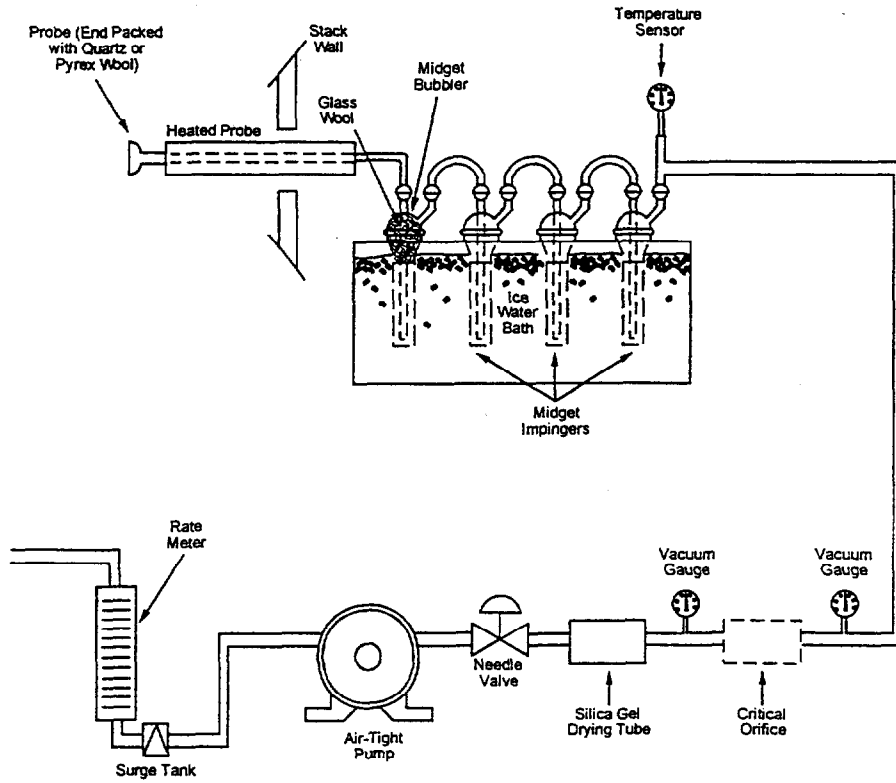

Figure 6-2. SO<sub>2</sub> sampling train using a critical orifice.

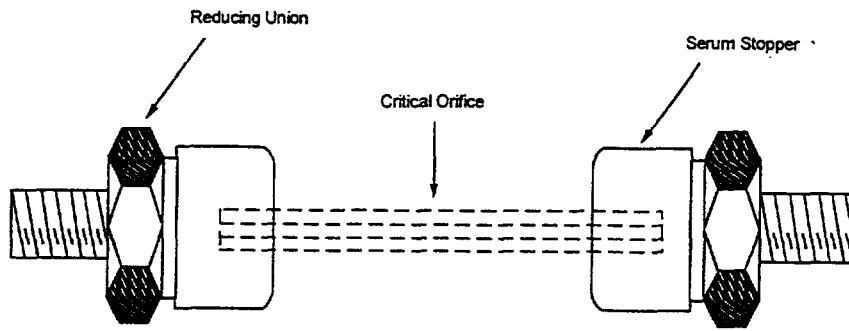

Figure 6-3. Critical orifice adaptation for Method 6 sampling train.

Date _____	Train ID _____		
Critical orifice size _____	Critical vacuum _____		
		<u>Pretest</u>	<u>Post-test</u>
Soap bubble meter volume, $V_{sb}$	cc	_____	_____
	$m^3$ (ft <sup>3</sup> )	_____	_____
Time, $\theta$	sec	_____	_____
	min	_____	_____
Barometric pressure, $P_{bar}$	mm Hg (in. Hg)	_____	_____
Ambient temperature, $t_{amb}$	°C (°F)	_____	_____
Inlet vacuum, $P_c$	mm Hg (in. Hg)	_____	_____
Outlet vacuum	mm Hg (in. Hg)	_____	_____
$V_{sb(std)}$	$m^3$ (ft <sup>3</sup> )	_____	_____
Flow rate, $Q_{std}$	$\frac{m^3}{min} \left( \frac{ft^3}{min} \right)$	_____	_____

Figure 6-4. Critical Orifice Calibration Data Sheet.





**APPENDIX B**

**METHOD 5 - DETERMINATION OF PARTICULATE EMISSIONS  
FROM STATIONARY SOURCES**

---

---

EMISSION MEASUREMENT TECHNICAL INFORMATION CENTER  
TEST METHOD

---

---

Method 5 - Determination of Particulate Emissions from Stationary Sources

1. PRINCIPLE AND APPLICABILITY

1.1 Principle. Particulate matter (PM) is withdrawn isokinetically from the source and collected on a glass fiber filter maintained at a temperature in the range of  $120 \pm 14^{\circ}\text{C}$  ( $248 \pm 25^{\circ}\text{F}$ ) or such other temperature as specified by an applicable subpart of the standards or approved by the Administrator, U.S. Environmental Protection Agency, for a particular application. The PM mass, which includes any material that condenses at or above the filtration temperature, is determined gravimetrically after removal of uncombined water.

1.2 Applicability. This method is applicable for the determination of PM emissions from stationary sources.

2. APPARATUS

2.1 Sampling Train. A schematic of the sampling train used in this method is shown in Figure 5-1. Complete construction details are given in APTD-0581 (Citation 2 in the Bibliography); commercial models of this train are also available. For changes from APTD-0581 and for allowable modifications of the train shown in Figure 5-1, see the following subsections.

The operating and maintenance procedures for the sampling train are described in APTD-0576 (Citation 3 in the Bibliography). Since correct usage is important in obtaining valid results, all users should read APTD-0576 and adopt the operating and maintenance procedures outlined in it, unless otherwise specified herein. The sampling train consists of the following components:

2.1.1 Probe Nozzle. Stainless steel (316) or glass with sharp, tapered leading edge. The angle of taper shall be  $\leq 30^{\circ}$ , and the taper shall be on the outside to preserve a constant internal diameter. The probe nozzle shall be of the button-hook or elbow design, unless otherwise specified by the Administrator. If made of stainless steel, the nozzle shall be constructed from seamless tubing; other materials of construction may be used, subject to the approval of the Administrator.

A range of nozzle sizes suitable for isokinetic sampling should be available, e.g., 0.32 to 1.27 cm (1/8 to 1/2 in.)--or larger if higher volume sampling trains are used--inside diameter (ID) nozzles in increments of 0.16 cm (1/16 in.). Each nozzle shall be calibrated according to the procedures outlined in Section 5.

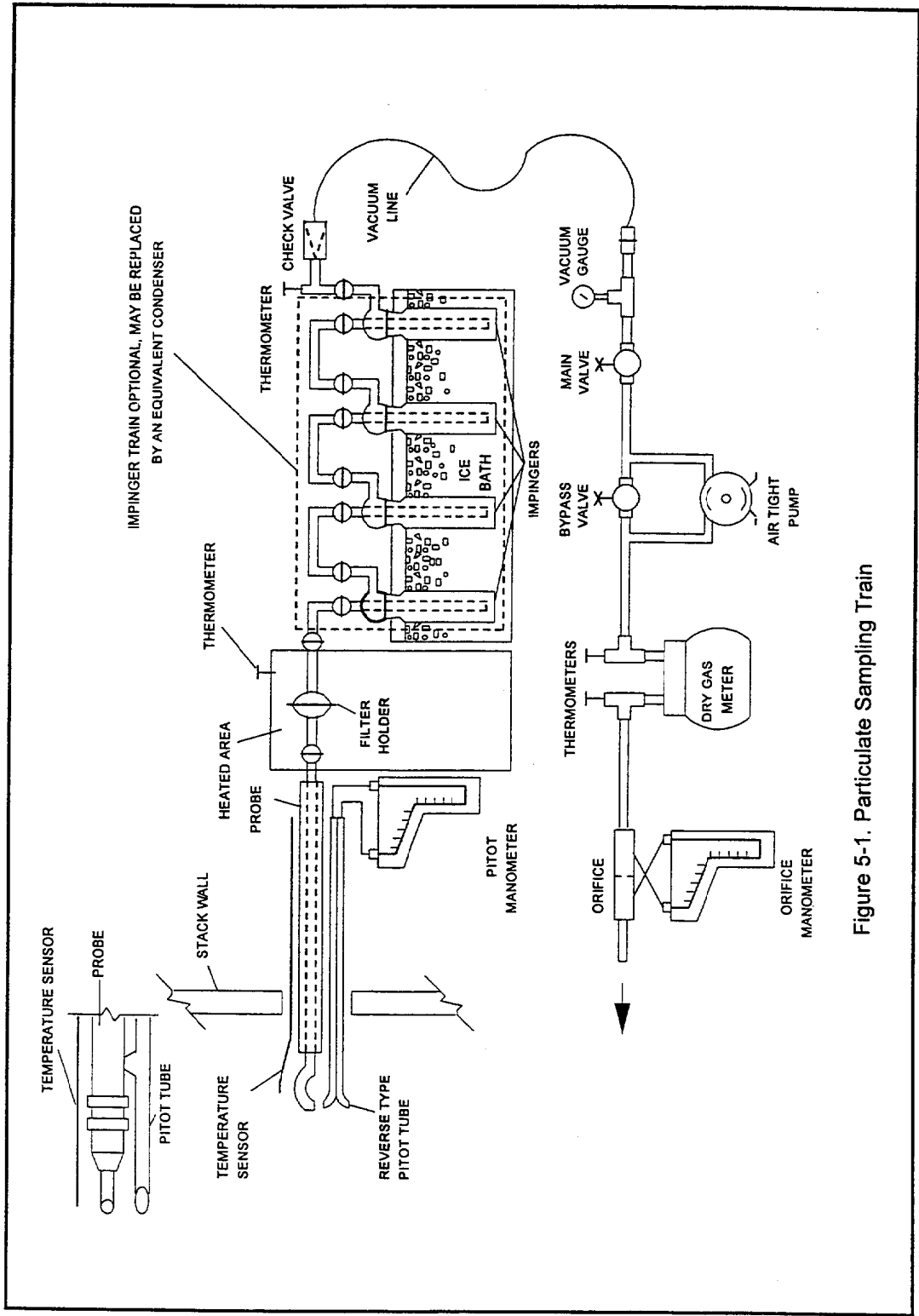

Figure 5-1. Particulate Sampling Train

**2.1.2 Probe Liner.** Borosilicate or quartz glass tubing with a heating system capable of maintaining a gas temperature at the exit end during sampling of  $120 \pm 14^{\circ}\text{C}$  ( $248 \pm 25^{\circ}\text{F}$ ), or such other temperature as specified by an applicable subpart of the standards or approved by the Administrator for a particular application. (The tester may opt to operate the equipment at a temperature lower than that specified.) Since the actual temperature at the outlet of the probe is not usually monitored during sampling, probes constructed according to APTD-0581 and utilizing the calibration curves of APTD-0576 (or calibrated according to the procedure outlined in APTD-0576) will be considered acceptable.

Either borosilicate or quartz glass probe liners may be used for stack temperatures up to about  $480^{\circ}\text{C}$  ( $900^{\circ}\text{F}$ ); quartz liners shall be used for temperatures between  $480$  and  $900^{\circ}\text{C}$  ( $900$  and  $1,650^{\circ}\text{F}$ ). Both types of liners may be used at higher temperatures than specified for short periods of time, subject to the approval of the Administrator. The softening temperature for borosilicate is  $820^{\circ}\text{C}$  ( $1,508^{\circ}\text{F}$ ), and for quartz it is  $1,500^{\circ}\text{C}$  ( $2,732^{\circ}\text{F}$ ).

Whenever practical, every effort should be made to use borosilicate or quartz glass probe liners. Alternatively, metal liners (e.g., 316 stainless steel, Incoloy 825 or other corrosion resistant metals) made of seamless tubing may be used, subject to the approval of the Administrator.

**NOTE:** Mention of trade names or specific products does not constitute endorsement of the Environmental Protection Agency.

**2.1.3 Pitot Tube.** Type S, as described in Section 2.1 of Method 2, or other device approved by the Administrator. The pitot tube shall be attached to the probe (as shown in Figure 5-1) to allow constant monitoring of the stack gas velocity. The impact (high pressure) opening plane of the pitot tube shall be even with or above the nozzle entry plane (see Method 2, Figure 2-6b) during sampling. The Type S pitot tube assembly shall have a known coefficient, determined as outlined in Section 4 of Method 2.

**2.1.4 Differential Pressure Gauge.** Inclined manometer or equivalent device (two), as described in Section 2.2 of Method 2. One manometer shall be used for velocity head ( $\Delta p$ ) readings, and the other, for orifice differential pressure readings.

**2.1.5 Filter Holder.** Borosilicate glass, with a glass frit filter support and a silicone rubber gasket. Other materials of construction (e.g., stainless steel, Teflon, Viton) may be used, subject to the approval of the Administrator. The holder design shall provide a positive seal against leakage from the outside or around the filter. The holder shall be attached immediately at the outlet of the probe (or cyclone, if used).

**2.1.6 Filter Heating System.** Any heating system capable of maintaining a temperature around the filter holder during the sampling of  $120 \pm 14^{\circ}\text{C}$

( $248 \pm 25^{\circ}\text{F}$ ), or such other temperature as specified by an applicable subpart of the standards or approved by the Administrator for a particular application. Alternatively, the tester may opt to operate the equipment at a temperature lower than that specified. A temperature gauge capable of measuring temperature to within  $3^{\circ}\text{C}$  ( $5.4^{\circ}\text{F}$ ) shall be installed so that the temperature around the filter holder can be regulated and monitored during sampling. Heating systems other than the one shown in APTD-0581 may be used.

**2.1.7 Condenser.** The following system shall be used to determine the stack gas moisture content: Four impingers connected in series with leak-free ground glass fittings or any similar leak-free noncontaminating fittings. The first, third, and fourth impingers shall be of the Greenburg-Smith design, modified by replacing the tip with a 1.3 cm ( $1/2$  in.) ID glass tube extending to about 1.3 cm ( $1/2$  in.) from the bottom of the flask. The second impinger shall be of the Greenburg-Smith design with the standard tip. Modifications (e.g., using a flexible connections between the impingers, using materials other than glass, or using flexible vacuum lines to connect the filter holder to the condenser) may be used, subject to the approval of the Administrator. The first and second impingers shall contain known quantities of water (Section 4.1.3), the third shall be empty, and the fourth shall contain a known weight of silica gel, or equivalent desiccant. A thermometer, capable of measuring temperature to within  $1^{\circ}\text{C}$  ( $2^{\circ}\text{F}$ ) shall be placed at the outlet of the fourth impinger for monitoring purposes.

Alternatively, any system that cools the sample gas stream and allows measurement of the water condensed and moisture leaving the condenser, each to within 1 ml or 1 g may be used, subject to the approval of the Administrator. Acceptable means are to measure the condensed water either gravimetrically or volumetrically and to measure the moisture leaving the condenser by: (1) monitoring the temperature and pressure at the exit of the condenser and using Dalton's law of partial pressures; or (2) passing the sample gas stream through a tared silica gel (or equivalent desiccant) trap with exit gases kept below  $20^{\circ}\text{C}$  ( $68^{\circ}\text{F}$ ) and determining the weight gain.

If means other than silica gel are used to determine the amount of moisture leaving the condenser, it is recommended that silica gel (or equivalent) still be used between the condenser system and pump to prevent moisture condensation in the pump and metering devices and to avoid the need to make corrections for moisture in the metered volume.

**NOTE:** If a determination of the PM collected in the impingers is desired in addition to moisture content, the impinger system described above shall be used, without modification. Individual States or control agencies requiring this information shall be contacted as to the sample recovery and analysis of the impinger contents.

**2.1.8 Metering System.** Vacuum gauge, leak-free pump, thermometers capable of measuring temperature to within 3°C (5.4°F), dry gas meter (DGM) capable of measuring volume to within 2 percent, and related equipment, as shown in Figure 5-1. Other metering systems capable of maintaining sampling rates within 10 percent of isokinetic and of determining sample volumes to within 2 percent may be used, subject to the approval of the Administrator. When the metering system is used in conjunction with a pitot tube, the system shall enable checks of isokinetic rates.

Sampling trains utilizing metering systems designed for higher flow rates than that described in APTD-0581 or APTD-0576 may be used provided that the specifications of this method are met.

**2.1.9 Barometer.** Mercury, aneroid, or other barometer capable of measuring atmospheric pressure to within 2.5 mm (0.1 in.) Hg.

**NOTE:** In many cases, the barometric reading may be obtained from a nearby National Weather Service station, in which case the station value (which is the absolute barometric pressure) shall be requested and an adjustment for elevation differences between the weather station and sampling point shall be applied at a rate of minus 2.5 mm (0.1 in.) Hg per 30 m (100 ft) elevation increase or vice versa for elevation decrease.

**2.1.10 Gas Density Determination Equipment.** Temperature sensor and pressure gauge, as described in Section 2.3 and 2.4 of Method 2, and gas analyzer, if necessary, as described in Method 3. The temperature sensor shall, preferably, be permanently attached to the pitot tube or sampling probe in a fixed configuration, such that the tip of the sensor extends beyond the leading edge of the probe sheath and does not touch any metal. Alternatively, the sensor may be attached just prior to use in the field. Note, however, that if the temperature sensor is attached in the field, the sensor must be placed in an interference-free arrangement with respect to the Type S pitot tube openings (see Method 2, Figure 2-7). As a second alternative, if a difference of not more than 1 percent in the average velocity measurement is to be introduced, the temperature gauge need not be attached to the probe or pitot tube. (This alternative is subject to the approval of the Administrator.)

**2.2 Sample Recovery.** The following items are needed:

**2.2.1 Probe-Liner and Probe-Nozzle Brushes.** Nylon bristle brushes with stainless steel wire handles. The probe brush shall have extensions (at least as long as the probe) of stainless steel, Nylon, Teflon, or similarly inert material. The brushes shall be properly sized and shaped to brush out the probe liner and nozzle.

**2.2.2 Wash Bottles.** Two. Glass wash bottles are recommended; polyethylene wash bottles may be used at the option of the tester. It is recommended that acetone not be stored in polyethylene bottles for longer than a month.

**2.2.3 Glass Sample Storage Containers.** Chemically resistant, borosilicate glass bottles, for acetone washes, 500-ml or 1000-ml. Screw cap liners shall either be rubber-backed-Teflon or shall be constructed so as to be leak-free and resistant to chemical attack by acetone. (Narrow mouth glass bottles have been found to be less prone to leakage.) Alternatively, polyethylene bottles may be used.

**2.2.4 Petri Dishes.** For filter samples, glass or polyethylene, unless otherwise specified by the Administrator.

**2.2.5 Graduated Cylinder and/or Balance.** To measure condensed water to within 1 ml or 1 g. Graduated cylinders shall have subdivisions no greater than 2 ml. Most laboratory balances are capable of weighing to the nearest 0.5 g or less. Any of these balances is suitable for use here and in Section 2.3.4.

**2.2.6 Plastic Storage Containers.** Air-tight containers to store silica gel.

**2.2.7 Funnel and Rubber Policeman.** To aid in transfer of silica gel to container; not necessary if silica gel is weighed in the field.

**2.2.8 Funnel.** Glass or polyethylene, to aid in sample recovery.

**2.3 Analysis.** For analysis, the following equipment is needed:

**2.3.1 Glass Weighing Dishes.**

**2.3.2 Desiccator.**

**2.3.3 Analytical Balance.** To measure to within 0.1 mg.

**2.3.4 Balance.** To measure to within 0.5 g.

**2.3.5 Beakers.** 250-ml.

**2.3.6 Hygrometer.** To measure the relative humidity of the laboratory environment.

**2.3.7 Temperature Gauge.** To measure the temperature of the laboratory environment.

### 3. REAGENTS

**3.1 Sampling.** The reagents used in sampling are as follows:

**3.1.1 Filters.** Glass fiber filters, without organic binder, exhibiting at least 99.95 percent efficiency (<0.05 percent penetration) on 0.3-micron dioctyl phthalate smoke particles. The filter efficiency test shall be conducted in accordance with ASTM Method D 2986-71 (Reapproved

1978)(incorporated by reference--see §60.17). Test data from the supplier's quality control program are sufficient for this purpose. In sources containing  $\text{SO}_2$  or  $\text{SO}_3$ , the filter material must be of a type that is unreactive to  $\text{SO}_2$  or  $\text{SO}_3$ . Citation 10 in the Bibliography may be used to select the appropriate filter.

**3.1.2 Silica Gel.** Indicating type, 6- to 16-mesh. If previously used, dry at  $175^\circ\text{C}$  ( $350^\circ\text{F}$ ) for 2 hours. New silica gel may be used as received. Alternatively, other types of desiccants (equivalent or better) may be used, subject to the approval of the Administrator.

**3.1.3 Water.** When analysis of the material caught in the impingers is required, deionized distilled water shall be used. Run blanks prior to field use to eliminate a high blank on test samples.

**3.1.4 Crushed Ice.**

**3.1.5 Stopcock Grease.** Acetone-insoluble, heat-stable silicone grease. This is not necessary if screw-on connectors with Teflon sleeves, or similar, are used. Alternatively, other types of stopcock grease may be used, subject to the approval of the Administrator.

**3.2 Sample Recovery.** Acetone--reagent grade,  $\leq 0.001$  percent residue, in glass bottles--is required. Acetone from metal containers generally has a high residue blank and should not be used. Sometimes, suppliers transfer acetone to glass bottles from metal containers; thus, acetone blanks shall be run prior to field use and only acetone with low blank values ( $\leq 0.001$  percent) shall be used. In no case shall a blank value of greater than 0.001 percent of the weight of acetone used be subtracted from the sample weight.

**3.3 Analysis.** Two reagents are required for the analysis:

**3.3.1 Acetone.** Same as in Section 3.2.

**3.3.2 Desiccant.** Anhydrous calcium sulfate, indicating type. Alternatively, other types of desiccants may be used, subject to the approval of the Administrator.

## 4. PROCEDURE

**4.1 Sampling.** The complexity of this method is such that, in order to obtain reliable results, testers should be trained and experienced with the test procedures.

**4.1.1 Pretest Preparation.** It is suggested that sampling equipment be maintained according to the procedures described in APTD-0576.



Weigh several 200- to 300-g portions of silica gel in air-tight containers to the nearest 0.5 g. Record the total weight of the silica gel plus container, on each container. As an alternative, the silica gel need not be preweighed, but may be weighed directly in its impinger or sampling holder just prior to train assembly.

Check filters visually against light for irregularities and flaws or pinhole leaks. Label filters of the proper diameter on the back side near the edge using numbering machine ink. As an alternative, label the shipping containers (glass or plastic petri dishes), and keep the filters in these containers at all times except during sampling and weighing.

Desiccate the filters at  $20 \pm 5.6^\circ\text{C}$  ( $68 \pm 10^\circ\text{F}$ ) and ambient pressure for at least 24 hours, and weigh at intervals of at least 6 hours to a constant weight, i.e.,  $\leq 0.5$ -mg change from previous weighing; record results to the nearest 0.1 mg. During each weighing the filter must not be exposed to the laboratory atmosphere for a period greater than 2 minutes and a relative humidity above 50 percent. Alternatively (unless otherwise specified by the Administrator), the filters may be oven dried at  $105^\circ\text{C}$  ( $220^\circ\text{F}$ ) for 2 to 3 hours, desiccated for 2 hours, and weighed. Procedures other than those described, which account for relative humidity effects, may be used, subject to the approval of the Administrator.

**4.1.2 Preliminary Determinations.** Select the sampling site and the minimum number of sampling points according to Method 1 or as specified by the Administrator. Determine the stack pressure, temperature, and the range of velocity heads using Method 2; it is recommended that a leak-check of the pitot lines (see Method 2, Section 3.1) be performed. Determine the moisture content using Approximation Method 4 or its alternatives for the purpose of making isokinetic sampling rate settings. Determine the stack gas dry molecular weight, as described in Method 2, Section 3.6; if integrated Method 3 sampling is used for molecular weight determination, the integrated bag sample shall be taken simultaneously with, and for the same total length of time as, the particulate sample run.

Select a nozzle size based on the range of velocity heads, such that it is not necessary to change the nozzle size in order to maintain isokinetic sampling rates. During the run, do not change the nozzle size. Ensure that the proper differential pressure gauge is chosen for the range of velocity heads encountered (see Section 2.2 of Method 2).

Select a suitable probe liner and probe length such that all traverse points can be sampled. For large stacks, consider sampling from opposite sides of the stack to reduce the length of probes.

Select a total sampling time greater than or equal to the minimum total sampling time specified in the test procedures for the specific industry such that (1) the sampling time per point is not less than 2 minutes (or some

greater time interval as specified by the Administrator), and (2) the sample volume taken (corrected to standard conditions) will exceed the required minimum total gas sample volume. The latter is based on an approximate average sampling rate.

The sampling time at each point shall be the same. It is recommended that the number of minutes sampled at each point be an integer or an integer plus one-half minute, in order to avoid timekeeping errors.

In some circumstances, e.g., batch cycles, it may be necessary to sample for shorter times at the traverse points and to obtain smaller gas sample volumes. In these cases, the Administrator's approval must first be obtained.

**4.1.3 Preparation of Collection Train.** During preparation and assembly of the sampling train, keep all openings where contamination can occur covered until just prior to assembly or until sampling is about to begin.

Place 100 ml of water in each of the first two impingers, leave the third impinger empty, and transfer approximately 200 to 300 g of preweighed silica gel from its container to the fourth impinger. More silica gel may be used, but care should be taken to ensure that it is not entrained and carried out from the impinger during sampling. Place the container in a clean place for later use in the sample recovery. Alternatively, the weight of the silica gel plus impinger may be determined to the nearest 0.5 g and recorded.

Using a tweezer or clean disposable surgical gloves, place a labeled (identified) and weighed filter in the filter holder. Be sure that the filter is properly centered and the gasket properly placed so as to prevent the sample gas stream from circumventing the filter. Check the filter for tears after assembly is completed.

When glass liners are used, install the selected nozzle using a Viton A O-ring when stack temperatures are less than 260°C (500°F) and an asbestos string gasket when temperatures are higher. See APTD-0576 for details. Other connecting systems using either 316 stainless steel or Teflon ferrules may be used. When metal liners are used, install the nozzle as above or by a leak-free direct mechanical connection. Mark the probe with heat resistant tape or by some other method to denote the proper distance into the stack or duct for each sampling point.

Set up the train as in Figure 5-1, using (if necessary) a very light coat of silicone grease on all ground glass joints, greasing only the outer portion (see APTD-0576) to avoid possibility of contamination by the silicone grease. Subject to the approval of the Administrator, a glass cyclone may be used between the probe and filter holder when the total particulate catch is expected to exceed 100 mg or when water droplets are present in the stack gas.

Place crushed ice around the impingers.

#### 4.1.4 Leak-Check Procedures.

**4.1.4.1 Pretest Leak-Check.** A pretest leak-check is recommended, but not required. If the tester opts to conduct the pretest leak-check, the following procedure shall be used.

After the sampling train has been assembled, turn on and set the filter and probe heating systems at the desired operating temperatures. Allow time for the temperatures to stabilize. If a Viton A O-ring or other leak-free connection is used in assembling the probe nozzle to the probe liner, leak-check the train at the sampling site by plugging the nozzle and pulling a 380 mm (15 in.) Hg vacuum.

**NOTE:** A lower vacuum may be used, provided that it is not exceeded during the test.

If an asbestos string is used, do not connect the probe to the train during the leak-check. Instead, leak-check the train by first plugging the inlet to the filter holder (cyclone, if applicable) and pulling a 380 mm (15 in.) Hg vacuum (see **NOTE** immediately above). Then connect the probe to the train, and leak-check at about 25 mm (1 in.) Hg vacuum; alternatively, the probe may be leak-checked with the rest of the sampling train, in one step, at 380 mm (15 in.) Hg vacuum. Leakage rates in excess of 4 percent of the average sampling rate or 0.00057 m<sup>3</sup>/min (0.02 cfm), whichever is less, are unacceptable.

The following leak-check instructions for the sampling train described in APTD-0576 and APTD-0581 may be helpful. Start the pump with bypass valve fully open and coarse adjust valve completely closed. Partially open the coarse adjust valve, and slowly close the bypass valve until the desired vacuum is reached. Do not reverse direction of bypass valve; this will cause water to back up into the filter holder. If the desired vacuum is exceeded, either leak-check at this higher vacuum or end the leak-check as shown below, and start over.

When the leak-check is completed, first slowly remove the plug from the inlet to the probe, filter holder, or cyclone (if applicable), and immediately turn off the vacuum pump. This prevents the water in the impingers from being forced backward into the filter holder and silica gel from being entrained backward into the third impinger.

**4.1.4.2 Leak-Checks During Sample Run.** If, during the sampling run, a component (e.g., filter assembly or impinger) change becomes necessary, a leak-check shall be conducted immediately before the change is made. The leak-check shall be done according to the procedure outlined in Section 4.1.4.1 above, except that it shall be done at a vacuum equal to or greater than the maximum value recorded up to that point in the test. If the leakage rate is found to be no greater than 0.00057 m<sup>3</sup>/min (0.02 cfm) or 4 percent of the average sampling rate (whichever is less), the results are acceptable, and no correction will need to be applied to the total volume of dry gas metered; if, however, a higher leakage rate is obtained, the tester shall either record the

leakage rate and plan to correct the sample volume as shown in Section 6.3 of this method, or shall void the sample run.

Immediately after component changes, leak-checks are optional; if such leak-checks are done, the procedure outlined in Section 4.1.4.1 above shall be used.

**4.1.4.3 Post-Test Leak-Check.** A leak-check is mandatory at the conclusion of each sampling run. The leak-check shall be done in accordance with the procedures outlined in Section 4.1.4.1, except that it shall be conducted at a vacuum equal to or greater than the maximum value reached during the sampling run. If the leakage rate is found to be no greater than 0.00057 m<sup>3</sup>/min (0.02 cfm) or 4 percent of the average sampling rate (whichever is less), the results are acceptable, and no correction need be applied to the total volume of dry gas metered. If, however, a higher leakage rate is obtained, the tester shall either record the leakage rate and correct the sample volume as shown in Section 6.3 of this method, or shall void the sampling run.

**4.1.5 Particulate Train Operation.** During the sampling run, maintain an isokinetic sampling rate (within 10 percent of true isokinetic unless otherwise specified by the Administrator) and a temperature around the filter of 120 ± 14°C (248 ± 25°F), or such other temperature as specified by an applicable subpart of the standards or approved by the Administrator.

For each run, record the data required on a data sheet such as the one shown in Figure 5-2. Be sure to record the initial dry gas meter (DGM) reading. Record the DGM readings at the beginning and end of each sampling time increment, when changes in flow rates are made, before and after each leak-check, and when sampling is halted. Take other readings required by Figure 5-2 at least once at each sample point during each time increment and additional readings when significant changes (20 percent variation in velocity head readings) necessitate additional adjustments in flow rate. Level and zero the manometer. Because the manometer level and zero may drift due to vibrations and temperature changes, make periodic checks during the traverse.

Clean the portholes prior to the test run to minimize the chance of sampling deposited material. To begin sampling, remove the nozzle cap, verify that the filter and probe heating systems are up to temperature, and that the pitot tube and probe are properly positioned. Position the nozzle at the first traverse point with the tip pointing directly into the gas stream. Immediately start the pump, and adjust the flow to isokinetic conditions. Nomographs are available, which aid in the rapid adjustment of the isokinetic sampling rate without excessive computations. These nomographs are designed for use when the Type S pitot tube coefficient is 0.85 ± 0.02, and the stack gas equivalent density (dry molecular weight) is equal to 29 ± 4. APTD-0576 details the procedure for using the nomographs. If  $C_p$  and  $M_d$  are outside the above stated ranges, do not use the nomographs unless appropriate steps (see Citation 7 in Bibliography) are taken to compensate for the deviations.

When the stack is under significant negative pressure (height of impinger stem), take care to close the coarse adjust valve before inserting the probe into the stack to prevent water from backing into the filter holder. If necessary, the pump may be turned on with the coarse adjust valve closed.

When the probe is in position, block off the openings around the probe and porthole to prevent unrepresentative dilution of the gas stream.

Traverse the stack cross-section, as required by Method 1 or as specified by the Administrator, being careful not to bump the probe nozzle into the stack walls when sampling near the walls or when removing or inserting the probe through the portholes; this minimizes the chance of extracting deposited material.

During the test run, make periodic adjustments to keep the temperature around the filter holder at the proper level; add more ice and, if necessary, salt to maintain a temperature of less than 20°C (68°F) at the condenser/silica gel outlet. Also, periodically check the level and zero of the manometer.

If the pressure drop across the filter becomes too high, making isokinetic sampling difficult to maintain, the filter may be replaced in the midst of the sample run. It is recommended that another complete filter assembly be used rather than attempting to change the filter itself. Before a new filter assembly is installed, conduct a leak-check (see Section 4.1.4.2). The total PM weight shall include the summation of the filter assembly catches.

A single train shall be used for the entire sample run, except in cases where simultaneous sampling is required in two or more separate ducts or at two or more different locations within the same duct, or, in cases where equipment failure necessitates a change of trains. In all other situations, the use of two or more trains will be subject to the approval of the Administrator.

Note that when two or more trains are used, separate analyses of the front-half and (if applicable) impinger catches from each train shall be performed, unless identical nozzle sizes were used on all trains, in which case, the front-half catches from the individual trains may be combined (as may the impinger catches) and one analysis of front-half catch and one analysis of impinger catch may be performed. Consult with the Administrator for details concerning the calculation of results when two or more trains are used.

At the end of the sample run, turn off the coarse adjust valve, remove the probe and nozzle from the stack, turn off the pump, record the final DGM meter reading, and conduct a post-test leak-check, as outlined in Section 4.1.4.3. Also, leak-check the pitot lines as described in Method 2, Section 3.1; the lines must pass this leak-check, in order to validate the velocity head data.

4.1.6 Calculation of Percent Isokinetic. Calculate percent isokinetic (see Calculations, Section 6) to determine whether the run was valid or another test

run should be made. If there was difficulty in maintaining isokinetic rates because of source conditions, consult with the Administrator for possible variance on the isokinetic rates.

**4.2 Sample Recovery.** Proper cleanup procedure begins as soon as the probe is removed from the stack at the end of the sampling period. Allow the probe to cool.

When the probe can be safely handled, wipe off all external PM near the tip of the probe nozzle, and place a cap over it to prevent losing or gaining PM. Do not cap off the probe tip tightly while the sampling train is cooling down as this would create a vacuum in the filter holder, thus drawing water from the impingers into the filter holder.

Before moving the sample train to the cleanup site, remove the probe from the sample train, wipe off the silicone grease, and cap the open outlet of the probe. Be careful not to lose any condensate that might be present. Wipe off the silicone grease from the filter inlet where the probe was fastened, and cap it. Remove the umbilical cord from the last impinger, and cap the impinger. If a flexible line is used between the first impinger or condenser and the filter holder, disconnect the line at the filter holder, and let any condensed water or liquid drain into the impingers or condenser. After wiping off the silicone grease, cap off the filter holder outlet and impinger inlet. Either ground-glass stoppers, plastic caps, or serum caps may be used to close these openings.

Transfer the probe and filter-impinger assembly to the cleanup area. This area should be clean and protected from the wind so that the chances of contaminating or losing the sample will be minimized.

Save a portion of the acetone used for cleanup as a blank. Take 200 ml of this acetone directly from the wash bottle being used, and place it in a glass sample container labeled "acetone blank."

Inspect the train prior to and during disassembly, and note any abnormal conditions. Treat the samples as follows:

**Container No. 1.** Carefully remove the filter from the filter holder, and place it in its identified petri dish container. Use a pair of tweezers and/or clean disposable surgical gloves to handle the filter. If it is necessary to fold the filter, do so such that the PM cake is inside the fold. Carefully transfer to the petri dish any PM and/or filter fibers that adhere to the filter holder gasket, by using a dry Nylon bristle brush and/or a sharp-edged blade. Seal the container.

**Container No. 2.** Taking care to see that dust on the outside of the probe or other exterior surfaces does not get into the sample, quantitatively recover PM or any condensate from the probe nozzle, probe fitting, probe liner, and front half of the filter holder by washing these components with acetone and placing

the wash in a glass container. Deionized distilled water may be used instead of acetone when approved by the Administrator and shall be used when specified by the Administrator; in these cases, save a water blank, and follow the Administrator's directions on analysis. Perform the acetone rinse as follows:

Carefully remove the probe nozzle, and clean the inside surface by rinsing with acetone from a wash bottle and brushing with a Nylon bristle brush. Brush until the acetone rinse shows no visible particles, after which make a final rinse of the inside surface with acetone.

Brush and rinse the inside parts of the Swagelok fitting with acetone in a similar way until no visible particles remain.

Rinse the probe liner with acetone by tilting and rotating the probe while squirting acetone into its upper end so that all inside surfaces will be wetted with acetone. Let the acetone drain from the lower end into the sample container. A funnel (glass or polyethylene) may be used to aid in transferring liquid washes to the container. Follow the acetone rinse with a probe brush. Hold the probe in an inclined position, squirt acetone into the upper end as the probe brush is being pushed with a twisting action through the probe; hold a sample container underneath the lower end of the probe, and catch any acetone and particulate matter that is brushed from the probe. Run the brush through the probe three times or more until no visible PM is carried out with the acetone or until none remains in the probe liner on visual inspection. With stainless steel or other metal probes, run the brush through in the above prescribed manner at least six times since metal probes have small crevices in which particulate matter can be entrapped. Rinse the brush with acetone, and quantitatively collect these washings in the sample container. After the brushing, make a final acetone rinse of the probe as described above.

It is recommended that two people clean the probe to minimize sample losses. Between sampling runs, keep brushes clean and protected from contamination.

After ensuring that all joints have been wiped clean of silicone grease, clean the inside of the front half of the filter holder by rubbing the surfaces with a Nylon bristle brush and rinsing with acetone. Rinse each surface three times or more if needed to remove visible particulate. Make a final rinse of the brush and filter holder. Carefully rinse out the glass cyclone, also (if applicable). After all acetone washings and particulate matter have been collected in the sample container, tighten the lid on the sample container so that acetone will not leak out when it is shipped to the laboratory. Mark the height of the fluid level to determine whether leakage occurred during transport. Label the container to identify clearly its contents.

**Container No. 3.** Note the color of the indicating silica gel to determine whether it has been completely spent, and make a notation of its condition. Transfer the silica gel from the fourth impinger to its original container, and seal. A funnel may make it easier to pour the silica gel without spilling. A rubber policeman may be used as an aid in removing the silica gel from the

impinger. It is not necessary to remove the small amount of dust particles that may adhere to the impinger wall and are difficult to remove. Since the gain in weight is to be used for moisture calculations, do not use any water or other liquids to transfer the silica gel. If a balance is available in the field, follow the procedure for Container No. 3 in Section 4.3.

**Impinger Water.** Treat the impingers as follows: Make a notation of any color or film in the liquid catch. Measure the liquid that is in the first three impingers to within 1 ml by using a graduated cylinder or by weighing it to within 0.5 g by using a balance (if one is available). Record the volume or weight of liquid present. This information is required to calculate the moisture content of the effluent gas.

Discard the liquid after measuring and recording the volume or weight, unless analysis of the impinger catch is required (see NOTE, Section 2.1.7).

If a different type of condenser is used, measure the amount of moisture condensed either volumetrically or gravimetrically.

Whenever possible, containers should be shipped in such a way that they remain upright at all times.

**4.3 Analysis.** Record the data required on a sheet such as the one shown in Figure 5-3. Handle each sample container as follows:

**Container No. 1.** Leave the contents in the shipping container or transfer the filter and any loose PM from the sample container to a tared glass weighing dish. Desiccate for 24 hours in a desiccator containing anhydrous calcium sulfate. Weigh to a constant weight, and report the results to the nearest 0.1 mg. For purposes of this Section, 4.3, the term "constant weight" means a difference of no more than 0.5 mg or 1 percent of total weight less tare weight, whichever is greater, between two consecutive weighings, with no less than 6 hours of desiccation time between weighings.

Alternatively, the sample may be oven dried at 105°C (220°F) for 2 to 3 hours, cooled in the desiccator, and weighed to a constant weight, unless otherwise specified by the Administrator. The tester may also opt to oven dry the sample at 105°C (220°F) for 2 to 3 hours, weigh the sample, and use this weight as a final weight.

**Container No. 2.** Note the level of liquid in the container, and confirm on the analysis sheet whether leakage occurred during transport. If a noticeable amount of leakage has occurred, either void the sample or use methods, subject to the approval of the Administrator, to correct the final results. Measure the liquid in this container either volumetrically to  $\pm 1$  ml or gravimetrically to  $\pm 0.5$  g. Transfer the contents to a tared 250-ml beaker, and evaporate to dryness at ambient temperature and pressure. Desiccate for 24 hours, and weigh to a constant weight. Report the results to the nearest 0.1 mg.



**Container No. 3.** Weigh the spent silica gel (or silica gel plus impinger) to the nearest 0.5 g using a balance. This step may be conducted in the field.

**"Acetone Blank" Container.** Measure the acetone in this container either volumetrically or gravimetrically. Transfer the acetone to a tared 250-ml beaker, and evaporate to dryness at ambient temperature and pressure. Desiccate for 24 hours, and weigh to a constant weight. Report the results to the nearest 0.1 mg.

**NOTE:** At the option of the tester, the contents of Container No. 2 as well as the acetone blank container may be evaporated at temperatures higher than ambient. If evaporation is done at an elevated temperature, the temperature must be below the boiling point of the solvent; also, to prevent "bumping," the evaporation process must be closely supervised, and the contents of the beaker must be swirled occasionally to maintain an even temperature. Use extreme care, as acetone is highly flammable and has a low flash point.

**4.4 Quality Control Procedures.** The following quality control procedures are suggested to check the volume metering system calibration values at the field test site prior to sample collection. These procedures are optional for the tester.

**4.4.1 Meter Orifice Check.** Using the calibration data obtained during the calibration procedure described in Section 5.3, determine the  $\Delta H_0$  for the metering system orifice. The  $\Delta H_0$  is the orifice pressure differential in units of in. H<sub>2</sub>O that correlates to 0.75 cfm of air at 528°R and 29.92 in. Hg. The  $\Delta H_0$  is calculated as follows:

$$\Delta H_0 = 0.0319 \Delta H \frac{T_m}{P_{\text{bar}}} \frac{1}{Y^2 V_m^2} \quad \text{Eq. 5-9}$$

where:

$\Delta H$  = Average pressure differential across the orifice meter, in. H<sub>2</sub>O.

$T_m$  = Absolute average DGM temperature, °R.

$P_{\text{bar}}$  = Barometric pressure, in. Hg.

$\theta$  = Total sampling time, min.

$Y$  = DGM calibration factor, dimensionless.

$V_m$  = Volume of gas sample as measured by DGM, dcf.

$$0.0319 = (0.0567 \text{ in. Hg/°R})(0.75 \text{ cfm})^2$$

Before beginning the field test (a set of three runs usually constitutes a field test), operate the metering system (i.e., pump, volume meter, and orifice) at the  $\Delta H_0$  pressure differential for 10 minutes. Record the volume collected, the DGM temperature, and the barometric pressure. Calculate a DGM calibration check value,  $Y_c$ , as follows:

$$Y_c = \frac{10}{V_m} \left[ 0.0319 \frac{T_m}{P_{\text{bar}}} \right]^{1/2} \quad \text{Eq. 5-10}$$

where:

$Y_c$  = DGM calibration check value, dimensionless.

10 = Run time, min.

Compare the  $Y_c$  value with the dry gas meter calibration factor  $Y$  to determine that:  $0.97Y < Y_c < 1.03Y$ . If the  $Y_c$  value is not within this range, the volume metering system should be investigated before beginning the test.

**4.4.2 Calibrated Critical Orifice.** A calibrated critical orifice, calibrated against a wet test meter or spirometer and designed to be inserted at the inlet of the sampling meter box, may be used as a quality control check by following the procedure of Section 7.2.

## 5. CALIBRATION

Maintain a laboratory log of all calibrations.

**5.1 Probe Nozzle.** Probe nozzles shall be calibrated before their initial use in the field. Using a micrometer, measure the inside diameter of the nozzle to the nearest 0.025 mm (0.001 in.). Make three separate measurements using different diameters each time, and obtain the average of the measurements. The difference between the high and low numbers shall not exceed 0.1 mm (0.004 in.). When nozzles become nicked, dented, or corroded, they shall be reshaped, sharpened, and recalibrated before use. Each nozzle shall be permanently and uniquely identified.

**5.2 Pitot Tube.** The Type S pitot tube assembly shall be calibrated according to the procedure outlined in Section 4 of Method 2.

### 5.3 Metering System.

**5.3.1 Calibration Prior to Use.** Before its initial use in the field, the metering system shall be calibrated as follows: Connect the metering system inlet to the outlet of a wet test meter that is accurate to within 1 percent.

Refer to Figure 5.5. The wet test meter should have a capacity of 30 liters/rev (1 ft<sup>3</sup>/rev). A spirometer of 400 liters (14 ft<sup>3</sup>) or more capacity, or equivalent, may be used for this calibration, although a wet test meter is usually more practical. The wet test meter should be periodically calibrated with a spirometer or a liquid displacement meter to ensure the accuracy of the wet test meter. Spirometers or wet test meters of other sizes may be used, provided that the specified accuracies of the procedure are maintained. Run the metering system pump for about 15 minutes with the orifice manometer indicating a median reading as expected in field use to allow the pump to warm up and to permit the interior surface of the wet test meter to be thoroughly wetted. Then, at each of a minimum of three orifice manometer settings, pass an exact quantity of gas through the wet test meter, and note the gas volume indicated by the DGM. Also note the barometric pressure, and the temperatures of the wet test meter, the inlet of the DGM, and the outlet of the DGM. Select the highest and lowest orifice settings to bracket the expected field operating range of the orifice. Use a minimum volume of 0.15 m<sup>3</sup> (5 cf) at all orifice settings. Record all the data on a form similar to Figure 5.6, and calculate Y, the DGM calibration factor, and  $\Delta H_o$ , the orifice calibration factor, at each orifice setting as shown on Figure 5.6. Allowable tolerances for individual Y and  $\Delta H_o$  values are given in Figure 5.6. Use the average of the Y values in the calculations in Section 6.

Before calibrating the metering system, it is suggested that a leak-check be conducted. For metering systems having diaphragm pumps, the normal leak-check procedure will not detect leakages within the pump. For these cases the following leak-check procedure is suggested: make a 10-minute calibration run at 0.00057 m<sup>3</sup>/min (0.02 cfm); at the end of the run, take the difference of the measured wet test meter and DGM volumes; divide the difference by 10, to get the leak rate. The leak rate should not exceed 0.00057 m<sup>3</sup>/min (0.02 cfm).

**5.3.2 Calibration After Use.** After each field use, the calibration of the metering system shall be checked by performing three calibration runs at a single, intermediate orifice setting (based on the previous field test), with the vacuum set at the maximum value reached during the test series. To adjust the vacuum, insert a valve between the wet test meter and the inlet of the metering system. Calculate the average value of the DGM calibration factor. If the value has changed by more than 5 percent, recalibrate the meter over the full range of orifice settings, as previously detailed.

Alternative procedures, e.g., rechecking the the orifice meter coefficient, may be used, subject to the approval of the Administrator.

**5.3.3 Acceptable Variation in Calibration.** If the DGM coefficient values obtained before and after a test series differ by more than 5 percent, the test series shall either be voided, or calculations for the test series shall be performed using whichever meter coefficient value (i.e., before or after) gives the lower value of total sample volume.

**5.4 Probe Heater Calibration.** The probe heating system shall be calibrated before its initial use in the field.

Use a heat source to generate air heated to selected temperatures that approximate those expected to occur in the sources to be sampled. Pass this air through the probe at a typical sample flow rate while measuring the probe inlet and outlet temperatures at various probe heater settings. For each air temperature generated, construct a graph of probe heating system setting versus probe outlet temperature. The procedure outlined in APTD-0576 can also be used. Probes constructed according to APTD-0581 need not be calibrated if the calibration curves in APTD-0576 are used. Also, probes with outlet temperatures monitoring capabilities do not require calibration.

**5.5 Temperature Gauges.** Use the procedure in Section 4.3 of Method 2 to calibrate in-stack temperature gauges. Dial thermometers, such as are used for the DGM and condenser outlet, shall be calibrated against mercury-in-glass thermometers.

**5.6 Leak Check of Metering System Shown in Figure 5-1.** That portion of the sampling train from the pump to the orifice meter should be leak checked prior to initial use and after each shipment. Leakage after the pump will result in less volume being recorded than is actually sampled. The following procedure is suggested (see Figure 5-4): Close the main valve on the meter box. Insert a one-hole rubber stopper with rubber tubing attached into the orifice exhaust pipe. Disconnect and vent the low side of the orifice manometer. Close off the low side orifice tap. Pressurize the system to 13 to 18 cm (5 to 7 in.) water column by blowing into the rubber tubing. Pinch off the tubing, and observe the manometer for one minute. A loss of pressure on the manometer indicates a leak in the meter box; leaks, if present, must be corrected.

**5.7 Barometer.** Calibrate against a mercury barometer.

## 6. CALCULATIONS

Carry out calculations, retaining at least one extra decimal figure beyond that of the acquired data. Round off figures after the final calculation. Other forms of the equations may be used as long as they give equivalent results.

### 6.1 Nomenclature.

$A_n$  = Cross-sectional area of nozzle,  $m^2$  ( $ft^2$ ).

$B_{ws}$  = Water vapor in the gas stream, proportion by volume.

$C_a$  = Acetone blank residue concentration, mg/g.

$C_s$  = Concentration of particulate matter in stack gas, dry basis, corrected to standard conditions, g/dscm (g/dscf).

- I = Percent of isokinetic sampling.
- $L_a$  = Maximum acceptable leakage rate for either a pretest leak check or for a leak check following a component change; equal to 0.00057 m<sup>3</sup>/min (0.02 cfm) or 4 percent of the average sampling rate, whichever is less.
- $L_i$  = Individual leakage rate observed during the leak check conducted prior to the "i<sup>th</sup>" component change (i = 1, 2, 3...n), m<sup>3</sup>/min (cfm).
- $L_p$  = Leakage rate observed during the post-test leak check, m<sup>3</sup>/min (cfm).
- $m_a$  = Mass of residue of acetone after evaporation, mg.
- $m_n$  = Total amount of particulate matter collected, mg.
- $M_w$  = Molecular weight of water, 18.0 g/g-mole (18.0 lb/lb-mole).
- $P_{bar}$  = Barometric pressure at the sampling site, mm Hg (in. Hg).
- $P_s$  = Absolute stack gas pressure, mm Hg (in. Hg).
- $P_{std}$  = Standard absolute pressure, 760 mm Hg (29.92 in. Hg).
- R = Ideal gas constant, 0.06236 [(mm Hg)(m<sup>3</sup>)/[(°K)(g-mole)] {21.85 [(in. Hg)(ft<sup>3</sup>)/[(°R)(lb-mole)]}].
- $T_m$  = Absolute average DGM temperature (see Figure 5-2), °K (°R).
- $T_s$  = Absolute average stack gas temperature (see Figure 5-2), °K (°R).
- $T_{std}$  = Standard absolute temperature, 293°K (528°R).
- $V_a$  = Volume of acetone blank, ml.
- $V_{aw}$  = Volume of acetone used in wash, ml.
- $V_{lc}$  = Total volume liquid collected in impingers and silica gel (see Figure 5-3), ml.
- $V_m$  = Volume of gas sample as measured by dry gas meter, dcm (dcf).
- $V_{m(std)}$  = Volume of gas sample measured by the dry gas meter, corrected to standard conditions, dscm (dscf).
- $V_{w(std)}$  = Volume of water vapor in the gas sample, corrected to standard conditions, scm (scf).

$v_s$  = Stack gas velocity, calculated by Method 2, Equation 2-9, using data obtained from Method 5, m/sec (ft/sec).

$W_a$  = Weight of residue in acetone wash, mg.

$Y$  = Dry gas meter calibration factor.

$\Delta H$  = Average pressure differential across the orifice meter (see Figure 5-2), mm H<sub>2</sub>O (in. H<sub>2</sub>O).

$\rho_a$  = Density of acetone, mg/ml (see label on bottle).

$\rho_w$  = Density of water, 0.9982 g/ml (0.002201 lb/ml).

$\theta$  = Total sampling time, min.

$\theta_1$  = Sampling time interval, from the beginning of a run until the first component change, min.

$\theta_i$  = Sampling time interval, between two successive component changes, beginning with the interval between the first and second changes, min.

$\theta_p$  = Sampling time interval, from the final (n<sup>th</sup>) component change until the end of the sampling run, min.

13.6 = Specific gravity of mercury.

60 = Sec/min.

100 = Conversion to percent.

**6.2 Average Dry Gas Meter Temperature and Average Orifice Pressure Drop.** See data sheet (Figure 5-2).

**6.3 Dry Gas Volume.** Correct the sample volume measured by the dry gas meter to standard conditions (20°C, 760 mm Hg or 68°F, 29.92 in. Hg) by using Equation 5-1.

$$V_{m(\text{std})} = V_m Y \left( \frac{T_{\text{std}}}{T_m} \right) \left[ \frac{P_{\text{bar}} + \frac{\Delta H}{13.6}}{P_{\text{std}}} \right] \quad \text{Eq. 5-1}$$

$$= K_1 V_m Y \frac{P_{\text{bar}} + \left( \frac{\Delta H}{13.6} \right)}{T_m}$$

where:

$$K_1 = 0.3858 \text{ } ^\circ\text{K/mm Hg for metric units,}$$

$$= 17.64 \text{ } ^\circ\text{R/in. Hg for English units.}$$

**NOTE:** Equation 5-1 can be used as written unless leakage rate observed during any of the mandatory leak checks (i.e., the post-test leak check or leak checks conducted prior to component changes) exceeds  $L_a$ . If  $L_p$  or  $L_i$  exceeds  $L_a$ , Equation 5-1 must be modified as follows:

(a) Case I. No component changes made during sampling run. In this case, replace  $V_m$  in Equation 5-1 with the expression:

$$[V_m - (L_p - L_a) \theta]$$

(b) Case II. One or more component changes made during the sampling run. In this case, replace  $V_m$  in Equation 5-1 by the expression:

$$\left[ V_m - (L_1 - L_a) \theta_1 - \sum_{i=2}^n (L_i - L_a) \theta_i - (L_p - L_a) \theta_p \right]$$

and substitute only for those leakage rates ( $L_i$  or  $L_p$ ) which exceed  $L_a$ .

#### 6.4 Volume of Water Vapor.

$$V_{w(\text{std})} = \frac{V_{lc} \rho_w R T_{\text{std}}}{M_w P_{\text{std}}} = K_2 V_{lc} \quad \text{Eq. 5-2}$$

where:

$$K_2 = 0.001333 \text{ m}^3/\text{ml for metric units,}$$

$$= 0.04707 \text{ ft}^3/\text{ml for English units.}$$

#### 6.5 Moisture Content.

$$B_{ws} = \frac{V_{w(\text{std})}}{V_{m(\text{std})} + V_{w(\text{std})}} \quad \text{Eq. 5-3}$$

**NOTE:** In saturated or water droplet-laden gas streams, two calculations of the moisture content of the stack gas shall be made, one from the impinger analysis (Equation 5-3), and a second from the assumption of saturated conditions. The lower of the two values of  $B_{ws}$  shall be considered correct. The procedure for determining the moisture content based upon assumption of saturated conditions is given in the **NOTE** of Section 1.2 of Method 4. For the purposes of this method, the average stack gas temperature from Figure 5-2 may be used to make this determination, provided that the accuracy of the in-stack temperature sensor is  $\pm 1^\circ\text{C}$  ( $2^\circ\text{F}$ ).

#### 6.6 Acetone Blank Concentration.

$$C_a = \frac{m_a}{V_a \rho_a} \quad \text{Eq. 5-4}$$

#### 6.7 Acetone Wash Blank.

$$W_a = C_a V_{aw} \rho_a \quad \text{Eq. 5-5}$$

**6.8 Total Particulate Weight.** Determine the total particulate matter catch from the sum of the weights obtained from Containers 1 and 2 less the acetone blank (see Figure 5-3).

**NOTE:** Refer to Section 4.1.5 to assist in calculation of results involving two or more filter assemblies or two or more sampling trains.

#### 6.9 Particulate Concentration.

$$C_s = (0.001 \text{ g/mg})(m_n / V_{m(\text{std})}) \quad \text{Eq. 5-6}$$

#### 6.10 Conversion Factors:

<u>From</u>	<u>To</u>	<u>Multiply by</u>
scf	$\text{m}^3$	0.02832
$\text{g}/\text{ft}^3$	$\text{gr}/\text{ft}^3$	15.43
$\text{g}/\text{ft}^3$	$\text{lb}/\text{ft}^3$	$2.205 \times 10^{-3}$
$\text{g}/\text{ft}^3$	$\text{g}/\text{m}^3$	35.31



## 6.11 Isokinetic Variation.

### 6.11.1 Calculation from Raw Data.

$$I = \frac{100 T_s [K_3 V_{Ic} + (V_m Y / T_m) (P_{bar} + \Delta H / 13.6)]}{60 \theta v_s P_s A_n} \quad \text{Eq. 5-7}$$

where:

$$\begin{aligned} K_3 &= 0.003454 \text{ [(mm Hg)(m}^3\text{)]/[ (ml)(}^\circ\text{K)] for metric units,} \\ &= 0.002669 \text{ [(in. Hg)(ft}^3\text{)]/[ (ml)(}^\circ\text{R)] for English units.} \end{aligned}$$

### 6.11.2 Calculation from Intermediate Values.

$$\begin{aligned} I &= \frac{100 T_s V_{m(std)} P_{std}}{60 T_{std} v_s \theta A_n P_s (1 - B_{ws})} \\ &= \frac{K_4 T_s V_{m(std)}}{P_s v_s A_n \theta (1 - B_{ws})} \end{aligned} \quad \text{Eq. 5-8}$$

where:

$$\begin{aligned} K_4 &= 4.320 \text{ for metric units,} \\ &= 0.09450 \text{ for English units.} \end{aligned}$$

**6.12 Acceptable Results.** If 90 percent  $\leq I \leq$  110 percent, the results are acceptable. If the PM results are low in comparison to the standard, and "I" is over 110 percent or less than 90 percent, the Administrator may opt to accept the results. Citation 4 in the Bibliography may be used to make acceptability judgments. If "I" is judged to unacceptable, reject the results, and repeat the test.

**6.13 Stack Gas Velocity and Volumetric Flow Rate.** Calculate the average stack gas velocity and volumetric flow rate, if needed, using data obtained in this method and the equations in Sections 5.2 and 5.3 of Method 2.

## 7. ALTERNATIVE PROCEDURES

**7.1 Dry Gas Meter as a Calibration Standard.** A DGM may be used as a calibration standard for volume measurements in place of the wet test meter

specified in Section 5.3, provided that it is calibrated initially and recalibrated periodically as follows:

### 7.1.1 Standard Dry Gas Meter Calibration.

7.1.1.1. The DGM to be calibrated and used as a secondary reference meter should be of high quality and have an appropriately sized capacity, e.g., 3 liters/rev (0.1 ft<sup>3</sup>/rev). A spirometer (400 liters or more capacity), or equivalent, may be used for this calibration, although a wet test meter is usually more practical. The wet test meter should have a capacity of 30 liters/rev (1 ft<sup>3</sup>/rev) and capable of measuring volume to within 1.0 percent; wet test meters should be checked against a spirometer or a liquid displacement meter to ensure the accuracy of the wet test meter. Spirometers or wet test meters of other sizes may be used, provided that the specified accuracies of the procedure are maintained.

7.1.1.2 Set up the components as shown in Figure 5.7. A spirometer, or equivalent, may be used in place of the wet test meter in the system. Run the pump for at least 5 minutes at a flow rate of about 10 liters/min (0.35 cfm) to condition the interior surface of the wet test meter. The pressure drop indicated by the manometer at the inlet side of the DGM should be minimized [no greater than 100 mm H<sub>2</sub>O (4 in. H<sub>2</sub>O) at a flow rate of 30 liters/min (1 cfm)]. This can be accomplished by using large diameter tubing connections and straight pipe fittings.

7.1.1.3 Collect the data as shown in the example data sheet (see Figure 5-8). Make triplicate runs at each of the flow rates and at no less than five different flow rates. The range of flow rates should be between 10 and 34 liters/min (0.35 and 1.2 cfm) or over the expected operating range.

7.1.1.4 Calculate flow rate,  $Q$ , for each run using the wet test meter volume,  $V_w$ , and the run time,  $\theta$ . Calculate the DGM coefficient,  $Y_{ds}$ , for each run. These calculations are as follows:

$$Q = K_1 \frac{P_{bar} V_w}{t_w + t_{std}} \ominus$$

$$Y_{ds} = \frac{V_w (t_{ds} + t_{std})}{V_{ds} (t_w + t_{std})} \frac{P_{bar}}{\left( P_{bar} + \frac{\Delta p}{13.6} \right)}$$

where:

- $K_1$  = 0.3858 for international system of units (SI); 17.64 for English units.
- $V_w$  = Wet test meter volume, liter (ft<sup>3</sup>).
- $V_{ds}$  = Dry gas meter volume, liter (ft<sup>3</sup>).
- $t_{ds}$  = Average dry gas meter temperature, °C (°F).
- $t_{std}$  = 273°C for SI units; 460°F for English units.
- $t_w$  = Average wet test meter temperature, °C (°F)
- $P_{bar}$  = Barometric pressure, mm Hg (in. Hg).
- $\Delta p$  = Dry gas meter inlet differential pressure, mm H<sub>2</sub>O (in. H<sub>2</sub>O).
- $\theta$  = Run time, min.

7.1.1.5 Compare the three  $Y_{ds}$  values at each of the flow rates and determine the maximum and minimum values. The difference between the maximum and minimum values at each flow rate should be no greater than 0.030. Extra sets of triplicate runs may be made in order to complete this requirement. In addition, the meter coefficients should be between 0.95 and 1.05. If these specifications cannot be met in three sets of successive triplicate runs, the meter is not suitable as a calibration standard and should not be used as such. If these specifications are met, average the three  $Y_{ds}$  values at each flow rate resulting in five average meter coefficients,  $Y_{ds}$ .

7.1.1.6 Prepare a curve of meter coefficient,  $Y_{ds}$ , versus flow rate,  $Q$ , for the DGM. This curve shall be used as a reference when the meter is used to calibrate other DGM's and to determine whether recalibration is required.

#### 7.1.2 Standard Dry Gas Meter Recalibration.

7.1.2.1 Recalibrate the standard DGM against a wet test meter or spirometer annually or after every 200 hours of operation, whichever comes first. This requirement is valid provided the standard DGM is kept in a laboratory and, if transported, cared for as any other laboratory instrument. Abuse to the standard meter may cause a change in the calibration and will require more frequent recalibrations.

7.1.2.2 As an alternative to full recalibration, a two-point calibration check may be made. Follow the same procedure and equipment arrangement as for a full recalibration, but run the meter at only two flow rates [suggested rates are 14 and 28 liters/min (0.5 and 1.0 cfm)]. Calculate the meter coefficients for these two points, and compare the values with the meter calibration curve. If the two coefficients are within 1.5 percent of the calibration curve values at the same flow rates, the meter need not be recalibrated until the next date for a recalibration check.

7.2 **Critical Orifices As Calibration Standards.** Critical orifices may be used as calibration standards in place of the wet test meter specified in Section 5.3, provided that they are selected, calibrated, and used as follows:

### 7.2.1 Selection of Critical Orifices.

7.2.1.1 The procedure that follows describes the use of hypodermic needles or stainless steel needle tubings which have been found suitable for use as critical orifices. Other materials and critical orifice designs may be used provided the orifices act as true critical orifices; i.e., a critical vacuum can be obtained, as described in Section 7.2.2.2.3. Select five critical orifices that are appropriately sized to cover the range of flow rates between 10 and 34 liters/min or the expected operating range. Two of the critical orifices should bracket the expected operating range.

A minimum of three critical orifices will be needed to calibrate a Method 5 DGM; the other two critical orifices can serve as spares and provide better selection for bracketing the range of operating flow rates. The needle sizes and tubing lengths shown below give the following approximate flow rates:

Gauge/cm	Flow rate, liters/min	Gauge/cm	Flow rate, liters/min
12/7.6	32.56	14/2.5	19.54
12/10.2	30.02	14/5.1	17.27
13/2.5	25.77	14/7.6	16.14
13/5.1	23.50	15/3.2	14.16
13/7.6	22.37	15/7.6	11.61
13/10.2	20.67	15/10.2	10.48

7.2.1.2 These needles can be adapted to a Method 5 type sampling train as follows: Insert a serum bottle stopper, 13- by 20-mm sleeve type, into a 1/2inch Swagelok quick connect. Insert the needle into the stopper as shown in Figure 5-9.

**7.2.2 Critical Orifice Calibration.** The procedure described in this section uses the Method 5 meter box configuration with a DGM as described in Section 2.1.8 to calibrate the critical orifices. Other schemes may be used, subject to the approval of the Administrator.

**7.2.2.1 Calibration of Meter Box.** The critical orifices must be calibrated in the same configuration as they will be used; i.e., there should be no connections to the inlet of the orifice.

**7.2.2.1.1** Before calibrating the meter box, leak check the system as follows: Fully open the coarse adjust valve, and completely close the by-pass valve. Plug the inlet. Then turn on the pump, and determine whether there is any leakage. The leakage rate shall be zero; i.e., no detectable movement of the DGM dial shall be seen for 1 minute.

**7.2.2.1.2** Check also for leakages in that portion of the sampling train between the pump and the orifice meter. See Section 5.6 for the procedure; make any corrections, if necessary. If leakage is detected, check for cracked gaskets, loose fittings, worn O-rings, etc., and make the necessary repairs.

**7.2.2.1.3** After determining that the meter box is leakless, calibrate the meter box according to the procedure given in Section 5.3. Make sure that the wet test meter meets the requirements stated in Section 7.1.1.1. Check the water level in the wet test meter. Record the DGM calibration factor, Y.

**7.2.2.2 Calibration of Critical Orifices.** Set up the apparatus as shown in Figure 5-10.

**7.2.2.2.1** Allow a warm-up time of 15 minutes. This step is important to equilibrate the temperature conditions through the DGM.

**7.2.2.2.2** Leak check the system as in Section 7.2.2.1.1. The leakage rate shall be zero.

**7.2.2.2.3** Before calibrating the critical orifice, determine its suitability and the appropriate operating vacuum as follows: Turn on the pump, fully open the coarse adjust valve, and adjust the by-

pass valve to give a vacuum reading corresponding to about half of atmospheric pressure. Observe the meter box orifice manometer reading,  $\Delta H$ . Slowly increase the vacuum reading until a stable reading is obtained on the meter box orifice manometer. Record the critical vacuum for each orifice. Orifices that do not reach a critical value shall not be used.

7.2.2.2.4 Obtain the barometric pressure using a barometer as described in Section 2.1.9. Record the barometric pressure,  $P_{bar}$ , in mm Hg (in. Hg).

7.2.2.2.5 Conduct duplicate runs at a vacuum of 25 to 50 mm Hg (1 to 2 in. Hg) above the critical vacuum. The runs shall be at least 5 minutes each. The DGM volume readings shall be in increments of complete revolutions of the DGM. As a guideline, the times should not differ by more than 3.0 seconds (this includes allowance for changes in the DGM temperatures) to achieve  $\pm 0.5$  percent in  $K'$ . Record the information listed in Figure 5-11.

7.2.2.2.6 Calculate  $K'$  using Equation 5-9.

$$K' = \frac{K_1 V_m Y \left( P_{bar} + \frac{\Delta H}{13.6} \right) \sqrt{T_{amb}}}{P_{bar} T_m \theta} \quad \text{Eq. 5-9}$$

where:

$$K' = \text{Critical orifice coefficient, } \frac{\text{m}^3 \text{K}^{1/2}}{(\text{mmHg})(\text{min})} \left[ \frac{\text{ft}^3 \text{R}^{1/2}}{(\text{in. Hg})(\text{min})} \right]$$

$T_{amb}$  = Absolute ambient temperature, °K (°R).

Average the  $K'$  values. The individual  $K'$  values should not differ by more than  $\pm 0.5$  percent from the average.

### 7.2.3 Using the Critical Orifices as Calibration Standards.

7.2.3.1 Record the barometric pressure.

7.2.3.2 Calibrate the metering system according to the procedure outlined in Sections 7.2.2.2.1 to 7.2.2.2.5. Record the information listed in Figure 512.

7.2.3.3 Calculate the standard volumes of air passed through the DGM and the critical orifices, and calculate the DGM calibration factor, Y, using the equations below:

$$V_{m(std)} = K_1 V_m \frac{P_{bar} + \frac{\Delta H}{13.6}}{T_m} \quad \text{Eq. 5-10}$$

$$V_{cr(std)} = K' \frac{P_{bar} \theta}{\sqrt{T_{amb}}} \quad \text{Eq. 5-11}$$

$$Y = \frac{V_{cr(std)}}{V_{m(std)}} \quad \text{Eq. 5-12}$$

where:

$V_{cr(std)}$  = Volume of gas sample passed through the critical orifice, corrected to standard conditions, dscm (dscf).

$K'$  = 0.3858 °K/mm Hg for metric units  
 = 17.64 °R/in. Hg for English units.

7.2.3.4 Average the DGM calibration values for each of the flow rates. The calibration factor, Y, at each of the flow rates should not differ by more than ±2 percent from the average.

7.2.3.5 To determine the need for recalibrating the critical orifices, compare the DGM Y factors obtained from two adjacent orifices each time a DGM is calibrated; for example, when checking orifice 13/2.5, use orifices 12/10.2 and 13/5.1. If any critical orifice yields a DGM Y factor differing by more than 2 percent from the others, recalibrate the critical orifice according to Section 7.2.2.2.

## 8. BIBLIOGRAPHY

1. Addendum to Specifications for Incinerator Testing at Federal Facilities. PHS, NCAPC. December 6, 1967.

2. Martin, Robert M. Construction Details of Isokinetic Source-Sampling Equipment. Environmental Protection Agency. Research Triangle Park, NC. APTD-0581. April 1971.
3. Rom, Jerome J. Maintenance, Calibration, and Operation of Isokinetic Source Sampling Equipment. Environmental Protection Agency. Research Triangle Park, NC. APTD-0576. March 1972.
4. Smith, W.S., R.T. Shigehara, and W.F. Todd. A Method of Interpreting Stack Sampling Data. Paper Presented at the 63rd Annual Meeting of the Air Pollution Control Association, St. Louis, MO. June 14-19, 1970.
5. Smith, W.S., et al. Stack Gas Sampling Improved and Simplified With New Equipment. APCA Paper No. 67-119. 1967.
6. Specifications for Incinerator Testing at Federal Facilities. PHS, NCAPC. 1967.
7. Shigehara, R.T. Adjustment in the EPA Nomograph for Different Pitot Tube Coefficients and Dry Molecular Weights. Stack Sampling News 2:4-11. October 1974.
8. Vollaro, R.F. A Survey of Commercially Available Instrumentation for the Measurement of Low-Range Gas Velocities. U.S. Environmental Protection Agency, Emission Measurement Branch. Research Triangle Park, NC. November 1976 (unpublished paper).
9. Annual Book of ASTM Standards. Part 26. Gaseous Fuels; Coal and Coke; Atmospheric Analysis. American Society for Testing and Materials. Philadelphia, PA. 1974. pp. 617-622.
10. Felix, L.G., G.I. Clinard, G.E. Lacy, and J.D. McCain. Inertial Cascade Impactor Substrate Media for Flue Gas Sampling. U.S. Environmental Protection Agency. Research Triangle Park, NC 27711. Publication No. EPA-600/7-77-060. June 1977. 83 p.
11. Westlin, P.R. and R.T. Shigehara. Procedure for Calibrating and Using Dry Gas Volume Meters as Calibration Standards. Source Evaluation Society Newsletter. 3(1):17-30. February 1978.
12. Lodge, J.P., Jr., J.B. Pate, B.E. Ammons, and G.A. Swanson. The Use of Hypodermic Needles as Critical Orifices in Air Sampling. J. Air Pollution Control Association. 16:197-200. 1966.





Plant \_\_\_\_\_  
 Date \_\_\_\_\_  
 Run No. \_\_\_\_\_  
 Filter No. \_\_\_\_\_  
 Amount liquid lost during transport \_\_\_\_\_  
 Acetone blank volume, ml \_\_\_\_\_  
 Acetone blank concentration, mg/mg (Equation 5-4) \_\_\_\_\_  
 Acetone wash blank, mg (Equation 5-5) \_\_\_\_\_

Container number	Weight of particulate collected, mg		
	Final weight	Tare weight	Weight gain
1.			
2.			
<b>Total</b>			
Less			
acetone blank			
<b>Weight of particulate matter</b>			

	Volume of liquid water collected	
	Impinger volume, ml	Silica gel weight, g
Final.....		
Initial.....		
Liquid collected		
Total volume collected....		g/ml

\*Convert weight of water to volume by dividing total weight increase by density of water (1 g/ml).

$$\frac{\text{Increase, g}}{(1\text{g/ml})} = \text{Volume water, ml}$$

Figure 5-3. Analytical Data Sheet.

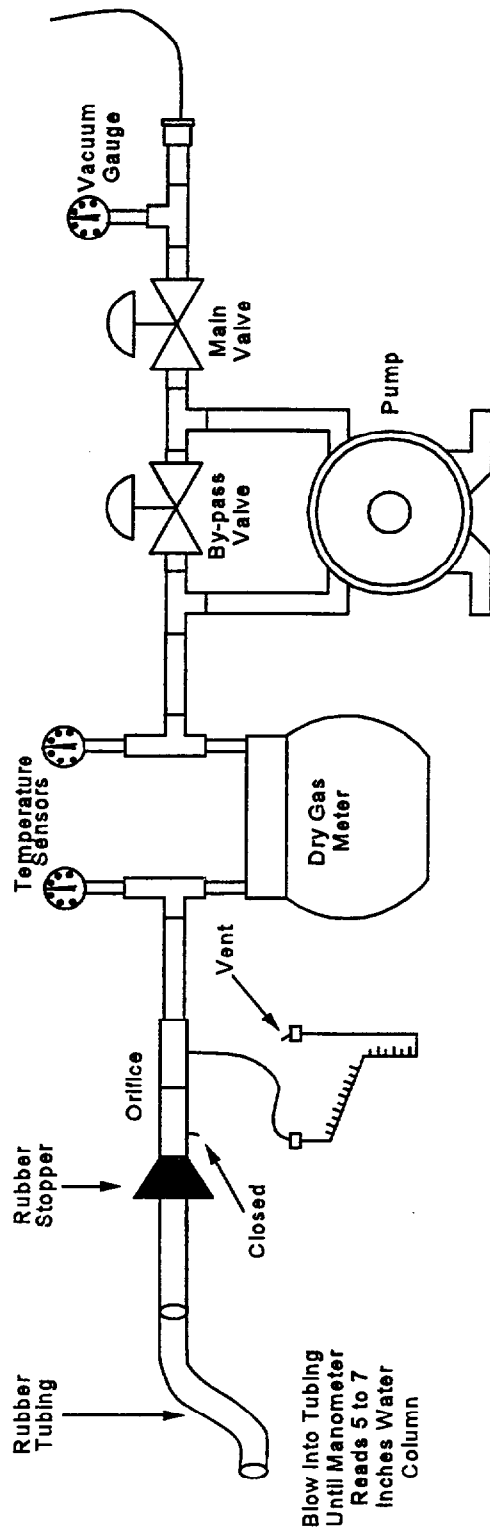

Figure 5-4. Leak Check of Meter Box.

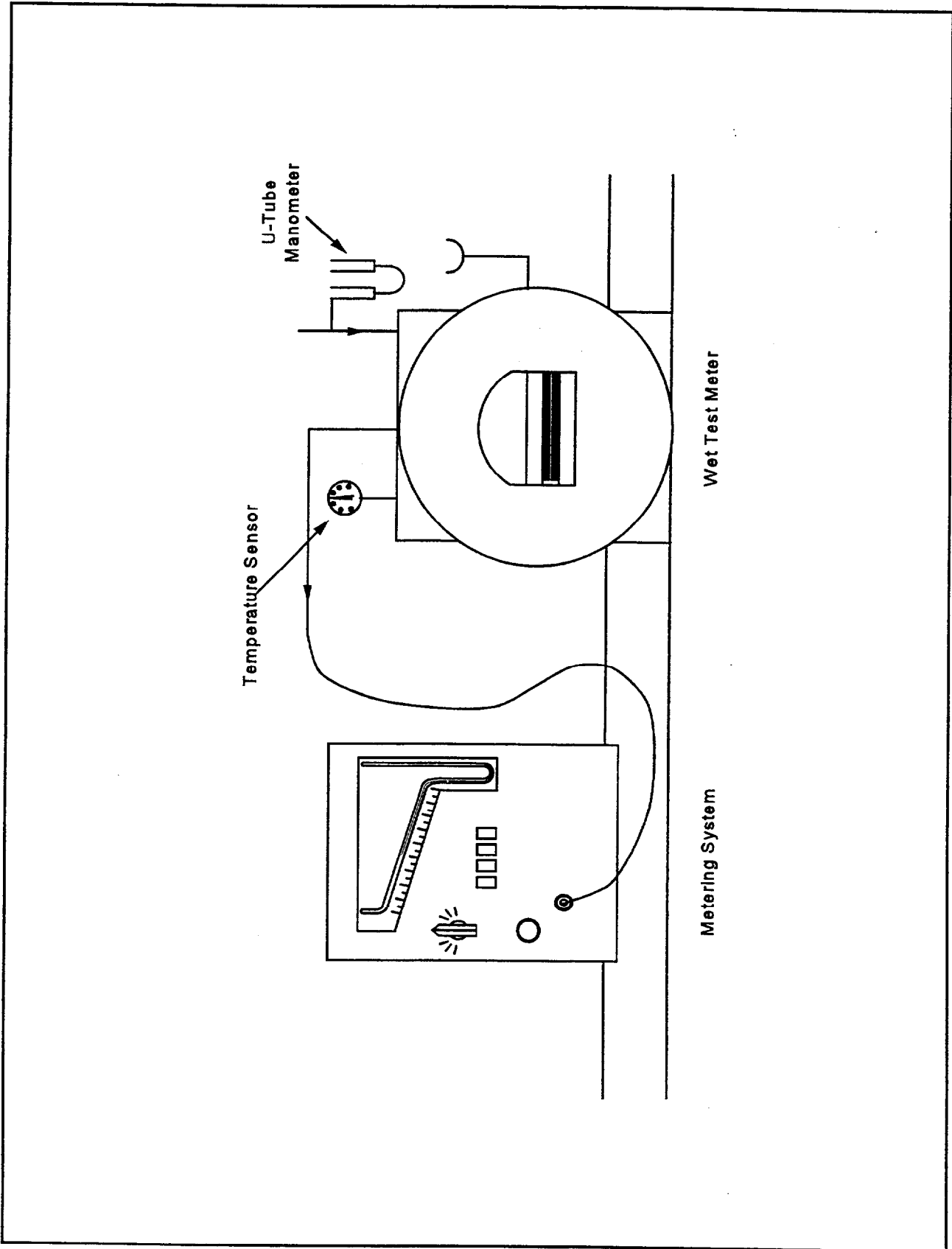
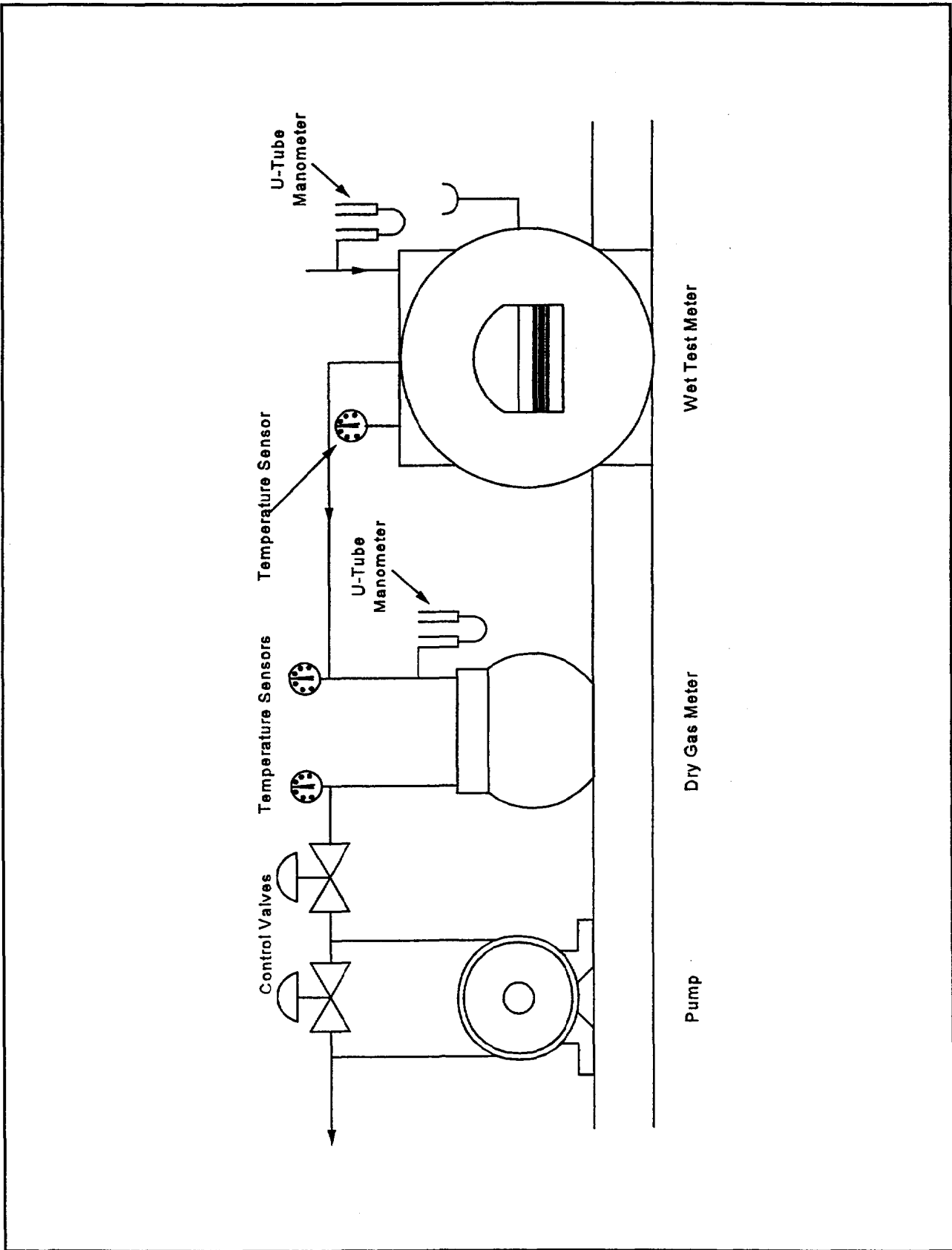

Figure 5-5. Equipment arrangement for metering system calibration.





**Figure 5-7. Equipment Arrangement for Dry Gas Meter Calibration.**

Date: \_\_\_\_\_  
 Dry Gas Meter Identification: \_\_\_\_\_  
 Barometric Pressure (P ): \_\_\_\_\_ in. Hg

Approximate Flow Rate (Q) cfm	Spirometer (Wet Meter) Gas Volume (V <sub>g</sub> ) ft <sup>3</sup>	Dry Gas Meter Volume (V <sub>g</sub> ) ft <sup>3</sup>	Temperatures			Dry Gas Meter Pressure (ΔP) in. H <sub>2</sub> O	Time (t) ft <sup>3</sup>	Flow Rate (Q) cfm	Meter Coefficient (Y <sub>m</sub> )	Average Meter Coefficient (Y <sub>a</sub> )
			Spirometer (Wet Meter) (t <sub>w</sub> ) °F	Dry Gas Meter Inlet (t <sub>i</sub> ) °F	Dry Gas Meter Outlet (t <sub>o</sub> ) °F					
0.40										
0.60										
0.80										
1.00										
1.20										

Figure 5-8. Example Data Sheet for Calibration of a Standard Dry Gas Meter for Method 5 Sampling Equipment (English units).

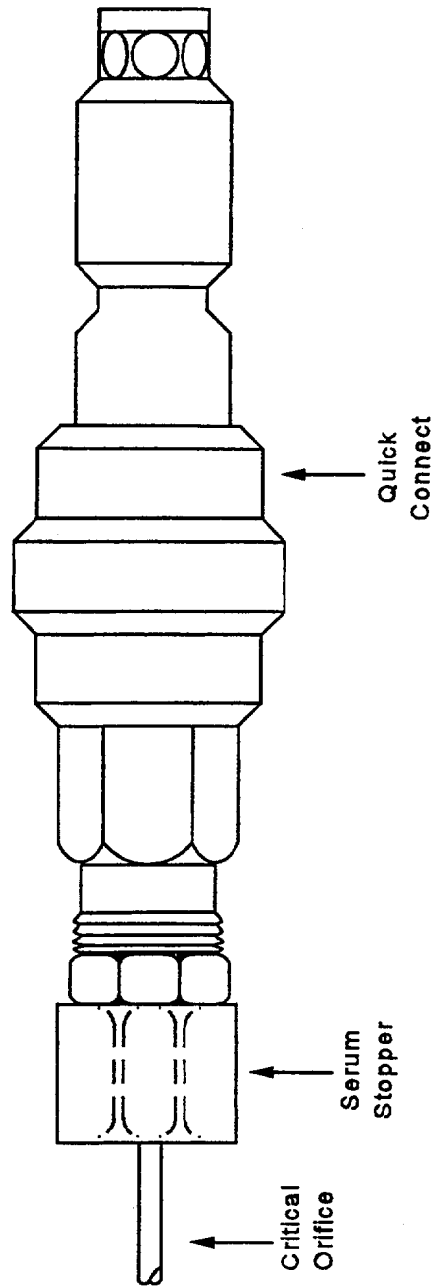
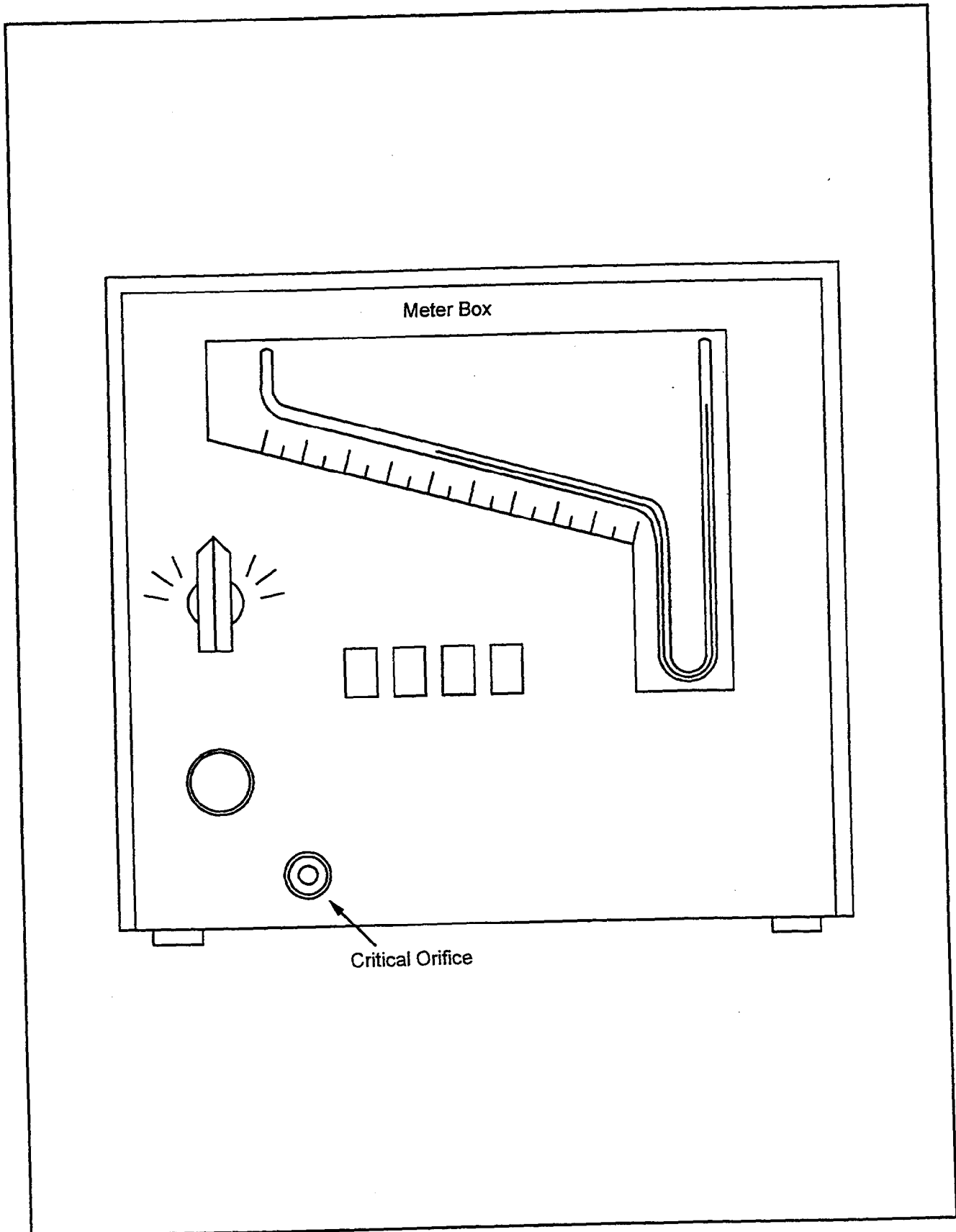

Figure 5-9. Critical Orifice Adaptation to Method 5 Metering System.





**Figure 5-10. Apparatus Setup.**

Date \_\_\_\_\_  
 Train ID \_\_\_\_\_  
 DGM cal. factor \_\_\_\_\_  
 Critical orifice ID \_\_\_\_\_

Dry gas meter		Run number	
		1	2
Final reading.....	m <sup>3</sup> (ft <sup>3</sup> ).....	.....	.....
Initial reading.....	m <sup>3</sup> (ft <sup>3</sup> ).....	.....	.....
Difference, V <sub>n</sub> .....	m <sup>3</sup> (ft <sup>3</sup> ).....	.....	.....
Inlet/Outlet temperatures:			
Initial.....	°C (°F).....	/	/
Final.....	°C (°F).....	/	/
Avg. Temperature, t <sub>n</sub>	°C (°F).....	.....	.....
Time, .....	min/sec.....	/	/
	min.....	.....	.....
Orifice man. rdg., H..	mm (in.) H <sub>2</sub> O..	.....	.....
Bar. pressure, P <sub>bar</sub> ....	mm (in.) Hg...	.....	.....
Ambient temperature, t <sub>amb</sub>	°C (°F).....	.....	.....
Pump vacuum.....	mm(in.) Hg...		
K' factor.....	.....	.....	.....
Average.....	.....	.....	.....
		.....	.....

Figure 5-11. Data sheet for determining K' factor.

Date \_\_\_\_\_  
 Train ID \_\_\_\_\_  
 Critical orifice ID \_\_\_\_\_  
 Critical orifice K' factor \_\_\_\_\_

Dry gas meter		Run number	
		1	2
Final reading.....	m <sup>3</sup> (ft <sup>3</sup> ).....	.....	.....
Initial reading.....	m <sup>3</sup> (ft <sup>3</sup> ).....	.....	.....
Difference, V <sub>m</sub> .....	m <sup>3</sup> (ft <sup>3</sup> ).....		
Inlet/outlet temperatures:		/	/
Initial.....	°C (°F).....	/	/
Final.....	°C (°F).....	.....	.....
Avg. Temperature, t <sub>m</sub> .....	°C (°F).....	/	/
Time, _ .....	min/sec.....	.....	.....
	min.....		
Orifice man. rdg., _H.....	min.....	.....	.....
Bar. pressure, P <sub>bar</sub> .....	mm (in.) H <sub>2</sub> O .....	.....	.....
	mm (in.) Hg .....	.....	.....
Ambient temperature, t <sub>amb</sub> .....	°C (°F) .....	.....	.....
Pump vacuum.....	mm (in.) Hg .....		
V <sub>m(std)</sub> .....	m <sup>3</sup> (ft <sup>3</sup> ).....		
V <sub>cr(std)</sub> .....	m <sup>3</sup> (ft <sup>3</sup> ).....		
DGM cal. factor, Y .....	.....		

Figure 5-12. Data sheet for determining DGM Y Factor.

**APPENDIX C**

**METHOD 8 - DETERMINATION OF SULFURIC ACID MIST AND  
SULFUR DIOXIDE EMISSIONS FROM STATIONARY SOURCES**

---

---

**EMISSION MEASUREMENT TECHNICAL INFORMATION CENTER  
NSPS TEST METHOD**

---

---

**Method 8 - Determination of Sulfuric Acid Mist and Sulfur  
Dioxide Emissions from Stationary Sources**

**1. PRINCIPLE AND APPLICABILITY**

**1.1 Principle.** A gas sample is extracted isokinetically from the stack. The sulfuric acid mist (including sulfur trioxide) and the sulfur dioxide are separated, and both fractions are measured separately by the barium-thorin titration method.

**1.2 Applicability.** This method is applicable for the determination of sulfuric acid mist [including sulfur trioxide (SO<sub>3</sub>) in the absence of other particulate matter] and sulfur dioxide (SO<sub>2</sub>) emissions from stationary sources. Collaborative tests have shown that the minimum detectable limits of the method are 0.05 mg/m<sup>3</sup> (0.03 x 10<sup>-7</sup> lb/ft<sup>3</sup>) for SO<sub>3</sub> and 1.2 mg/m<sup>3</sup> (0.74 x 10<sup>-7</sup> lb/ft<sup>3</sup>) for SO<sub>2</sub>. No upper limits have been established. Based on theoretical calculations for 200 ml of 3 percent hydrogen peroxide solution, the upper concentration limit for SO<sub>2</sub> in a 1.0 m<sup>3</sup> (35.3 ft<sup>3</sup>) gas sample is about 12,500 mg/m<sup>3</sup> (7.7 x 10<sup>-4</sup> lb/ft<sup>3</sup>). The upper limit can be extended by increasing the quantity of peroxide solution in the impingers.

Possible interfering agents of this method are fluorides, free ammonia, and dimethyl aniline. If any of these interfering agents are present (this can be determined by knowledge of the process), alternative methods, subject to the approval of the Administrator, U.S. Environmental Protection Agency, are required.

Filterable particulate matter may be determined along with SO<sub>3</sub> and SO<sub>2</sub> (subject to the approval of the Administrator) by inserting a heated glass fiber filter between the probe and isopropanol impinger (see Section 2.1 of Method 6). If this option is chosen, particulate analysis is gravimetric only; H<sub>2</sub>SO<sub>4</sub> acid mist is not determined separately.

**2. APPARATUS**

**2.1 Sampling.** A schematic of the sampling train used in this method is shown in Figure 8-1; it is similar to the Method 5 train, except that the filter position is different, and the filter holder does not have to be heated. Commercial models of this train are available. For those who desire to build their own, however, complete construction details are described in APTD-0581. Changes from the APTD-0581 document and allowable modifications to figure 8-1 are discussed in the following subsections.

The operating and maintenance procedures for the sampling train are described in APTD-0576. Since correct usage is important in obtaining valid results, all users should read the APTD-0576 document and adopt the operating and maintenance procedures outlined in it, unless otherwise specified herein. Further details and guidelines on operation and maintenance are given in Method 5 and should be read and followed whenever they are applicable.

---

---

Prepared by Emission Measurement Center  
Technical Support Division, OAQPS, EPA

EMTIC TM-008  
October 25, 1990

---

---

- 2.1.1 **Probe Nozzle.** Same as Method 5, Section 2.1.1.
- 2.1.2 **Probe Liner.** Borosilicate or quartz glass, with a heating system to prevent visible condensation during sampling. Do not use metal probe liners.
- 2.1.3 **Pitot Tube.** Same as Method 5, Section 2.1.3.
- 2.1.4 **Differential Pressure Gauge.** Same as Method 5, Section 2.1.4.
- 2.1.5 **Filter Holder.** Borosilicate glass, with a glass frit filter support and a silicone rubber gasket. Other gasket materials, e.g., Teflon or Viton, may be used subject to the approval of the Administrator. The holder design shall provide a positive seal against leakage from the outside or around the filter. The filter holder shall be placed between the first and second impingers.  
Note: Do not heat the filter holder.
- 2.1.6 **Impingers.** Four, as shown in Figure 8-1. The first and third shall be of Greenburg-Smith design with standard tips. The second and fourth shall be of Greenburg-Smith design modified by replacing the insert with an approximately 13-mm (0.5-in.) ID glass tube, having an unstricted tip located 13 mm (0.5 in.) from the bottom of the flask. Similar collection systems, subject to the approval of the Administrator, may be used.
- 2.1.7 **Metering System.** Same as Method 5, Section 2.1.8.
- 2.1.8 **Barometer.** Same as Method 5, Section 2.1.9.
- 2.1.9 **Gas Density Determination Equipment.** Same as Method 5, Section 2.1.10.
- 2.1.10 **Temperature Gauge.** Thermometer, or equivalent, to measure the temperature of the gas leaving the impinger train to within 1°C (2°F).
- 2.2 **Sample Recovery.**
- 2.2.1 **Wash Bottles.** Polyethylene or glass, 500-ml (two).
- 2.2.2 **Graduated Cylinders.** 250-ml, 1-liter. (Volumetric flasks may also be used.)
- 2.2.3 **Storage Bottles.** Leak-free polyethylene bottles, 1-liter size (two for each sampling run).
- 2.2.4 **Trip Balance.** 500-g capacity, to measure to  $\pm 0.5$  g (necessary only if a moisture content analysis is to be done).
- 2.3 **Analysis.**
- 2.3.1 **Pipettes.** Volumetric 25-ml, 100-ml.
- 2.3.2 **Burette.** 50-ml.
- 2.3.3 **Erlenmeyer Flask.** 250-ml (one for each sample, blank, and standard).
- 2.3.4 **Graduated Cylinder.** 100-ml.
- 2.3.5 **Trip Balance.** 500 g capacity, to measure to  $\pm 0.5$  g.

2.3.6 **Dropping Bottle.** To add indicator solution, 125-ml size.

### 3. REAGENTS

Unless otherwise indicated, all reagents are to conform to the specifications established by the Committee on Analytical Reagents of the American Chemical Society, where such specifications are available. Otherwise, use the best available grade.

#### 3.1 Sampling.

3.1.1 **Filters.** Same as in Method 5, Sections 3.1.1.

3.1.2 **Silica Gel.** Same as Method 5, Section 3.1.2.

3.1.3 **Water.** Deionized, distilled to conform to ASTM Specification D1193-77, Type 3 (incorporated by reference - see §60.17). At the option of the analyst, the  $\text{KMnO}_4$  test for oxidizable organic matter may be omitted when high concentrations of organic matter are not expected to be present.

3.1.4 **Isopropanol, 80 Percent.** Mix 800 ml of isopropanol with 200 ml of deionized, distilled water.

**Note:** Experience has shown that only A.C.S. grade isopropanol is satisfactory. Tests have shown that isopropanol obtained from commercial sources occasionally has peroxide impurities that will cause erroneously high sulfuric acid mist measurement. Use the following test for detecting peroxides in each lot of isopropanol: Shake 10 ml of the isopropanol with 10 ml of freshly prepared 10 percent potassium iodide solution. Prepare a blank by similarly treating 10 ml of distilled water. After 1 minute, read the absorbance on a spectrophotometer at 352 nanometers. If the absorbance exceeds 0.1, the isopropanol shall not be used. Peroxides may be removed from isopropanol by redistilling, or by passage through a column of activated alumina. However, reagent grade isopropanol with suitably low peroxide levels is readily available from commercial sources; therefore, rejection of contaminated lots may be more efficient than following the peroxide removal procedure.

3.1.5 **Hydrogen Peroxide, 3 Percent.** Dilute 100 ml of 30 percent hydrogen peroxide to 1 liter with deionized, distilled water. Prepare fresh daily.

3.1.6 **Crushed Ice.**

#### 3.2 Sample Recovery.

3.2.1 **Water.** Same as in Section 3.1.3.

3.2.2 **Isopropanol, 80 Percent.** Same as in Section 3.1.4.

#### 3.3 Analysis.

3.3.1 **Water.** Same as 3.1.3.

3.3.2 **Isopropanol, 100 percent.**

3.3.3 **Thorin Indicator.** 1-(o-arsonophenylazo) 2-naphthol-3, 6-disulfonic acid, disodium salt, or equivalent. Dissolve 0.20 g in 100 ml of deionized, distilled water.

**3.3.4 Barium Perchlorate (0.0100 Normal).** Dissolve 1.95 g of barium perchlorate trihydrate ( $\text{Ba}(\text{ClO}_4)_2 \cdot 3\text{H}_2\text{O}$ ) in 200 ml deionized, distilled water, and dilute to 1 liter with isopropanol; 1.22 g of barium chloride dihydrate ( $\text{Ba}(\text{ClO}_4)_2 \cdot 2\text{H}_2\text{O}$ ) may be used instead of the barium perchlorate. Standardize with sulfuric acid as in Section 5.2. This solution must be protected against evaporation at all times.

**3.3.5 Sulfuric Acid Standard (0.0100 N).** Purchase or standardize to  $\pm 0.0002$  N against 0.0100 N NaOH that has previously been standardized against primary standard potassium acid phthalate.

**3.3.6 Quality Assurance Audit Samples.** Same as in Method 6, Section 3.3.6.

#### 4. PROCEDURE

##### 4.1 Sampling.

**4.1.1 Pretest Preparation.** Follow the procedure in Method 5, Section 4.1.1; filters should be inspected but need not be desiccated, weighed, or identified.

If the effluent gas can be considered dry, i.e., moisture free, the silica gel need not be weighed.

**4.1.2 Preliminary Determinations.** Follow the procedure in Method 5, Section 4.1.2.

**4.1.3 Preparation of Collection Train.** Follow the procedure in Method 5, Section 4.1.3 (except for the second paragraph and other obviously inapplicable parts), and use Figure 8-1 instead of Figure 5-1. Replace the second paragraph with: Place 100 ml of 80 percent isopropanol in the first impinger, 100 ml of 3 percent hydrogen peroxide in both the second and third impingers; retain a portion of each reagent for use as a blank solution. Place about 200 g of silica gel in the fourth impinger. (Note: If moisture content is to be determined by impinger analysis, weigh each of the first three impingers (plus absorbing solution) to the nearest 0.5 g, and record these weights. Weigh also the silica gel (or silica gel plus container) to the nearest 0.5 g, and record.)

**4.1.4 Pretest Leak-Check Procedure.** Follow the basic procedure in Method 5, Section 4.1.4.1, noting that the probe heater shall be adjusted to the minimum temperature required to prevent condensation, and also that verbage such as "...plugging the inlet to the filter holder..." shall be replaced by "...plugging the inlet to the first impinger..." The pretest leak-check is optional.

##### 4.1.5 Train Operation.

Follow the basic procedures in Method 5, Section 4.1.5, in conjunction with the following special instructions. Record the data on a sheet similar to the one in Figure 8-2. (or use Figure 5-2 in Method 5) The sampling rate shall not exceed 0.030 m<sup>3</sup>/min (1.0 cfm) during the run. Periodically during the test, observe the connecting line between the probe and first impinger for signs of condensation. If it does occur, adjust the probe heater setting upward to the minimum temperature required to prevent condensation. If component changes become necessary during a run, a leak-check shall be done immediately before each change, according to the procedure outlined in Section 4.1.4.2 of Method 5 (with appropriate modifications, as mentioned in Section 4.1.4 of this method); record all leak rates. If the leakage rate(s) exceeds the specified rate, the tester shall either void the run or shall plan to correct the sample volume as outlined in Section 6.3 of Method 5. Immediately after component changes,



leak-checks are optional. If these leak-checks are done, the procedure in Section 4.1.4.1 of Method 5 (with appropriate modifications) shall be used.

After turning off the pump and recording the final readings at the conclusion of each run, remove the probe from the stack. Conduct a post-test (mandatory) leak-check as in Section 4.1.4.3 of Method 5 (with appropriate modifications), and record the leak rate. If the post-test leakage rate exceeds the specified acceptable rate, the tester shall either correct the sample volume, as in Section 6.3 of Method 5, or shall void the run.

Drain the ice bath and, with the probe disconnected, purge the remaining part of the train by drawing clean ambient air through the system for 15 minutes at the average flow rate used for sampling. (Note: Clean ambient air can be provided by passing air through a charcoal filter. At the option of the tester, ambient air (without cleaning) may be used.)

**4.1.6 Calculation of Percent Isokinetic.** Follow the procedure in Method 5, Section 4.1.6.

## 4.2 Sample Recovery.

**4.2.1 Container No. 1.** If a moisture content analysis is to be done, weigh the first impinger plus contents to the nearest 0.5 g, and record this weight.

Transfer the contents of the first impinger to a 250-ml graduated cylinder. Rinse the probe, first impinger, all connecting glassware before the filter, and the front half of the filter holder with 80-percent isopropanol. Add the filter to the solution, mix, and transfer to the storage container. Protect the solution against evaporation. Mark the level of liquid on the container, and identify the sample container.

**4.2.2 Container No. 2.** If a moisture content analysis is to be done, weigh the second and third impingers (plus contents) to the nearest 0.5 g, and record the weights. Also, weigh the spent silica gel (or silica gel plus impinger) to the nearest 0.5 g, and record.

Transfer the solutions from the second and third impingers to a 1-liter graduated cylinder. Rinse all connecting glassware (including back half of filter holder) between the filter and silica gel impinger with water, and add this rinse water to the cylinder. Dilute to 1 liter with water. Transfer the solution to a storage container. Mark the level of liquid on the container. Seal and identify the sample container.

**4.3 Analysis.** Note the level of the liquid in Containers No. 1 and 2, and confirm whether any sample was lost during shipment; note this on the analytical data sheet. If a noticeable amount of leakage has occurred, either void the sample or use methods, subject to the approval of the Administrator, to correct the final results.

**4.3.1 Container No. 1.** Shake the container holding the isopropanol solution and the filter. If the filter breaks up, allow the fragments to settle for a few minutes before removing a sample. Pipette a 100-ml aliquot of this solution into a 250-ml Erlenmeyer flask, add 2 to 4 drops of thiorin indicator, and titrate to a pink endpoint using 0.0100 N barium perchlorate. Repeat the titration with a second aliquot of sample, and average the titration values. Replicate titrations must agree within 1 percent or 0.2 ml, whichever is greater.

4.3.2 **Container No. 2.** Thoroughly mix the solution in the container holding the contents of the second and third impingers. Pipette a 10-ml aliquot of sample into a 250-ml Erlenmeyer flask. Add 40 ml of isopropanol, 2 to 4 drops of thorin indicator, and titrate to a pink endpoint using 0.0100 N barium perchlorate. Repeat the titration with a second aliquot of sample, and average the titration values. Replicate titrations must agree within 1 percent or 0.2 ml, whichever is greater.

4.3.3 **Blanks.** Prepare blanks by adding 2 to 4 drops of thorin indicator to 100 ml of 80 percent isopropanol. Titrate the blanks in the same manner as the samples.

4.4 **Quality Control Procedures.** Same as in Method 5, Section 4.4.

4.5 **Audit Sample Analysis.** Same as in Method 6, Section 4.4.

## 5. CALIBRATION

5.1 Calibrate equipment using the procedures specified in the following sections of Method 5: Section 5.3 (metering system), Section 5.5 (temperature gauges), and Section 5.7 (barometer). Note that the recommended leak-check of the metering system, described in Section 5.6 of Method 5, also applies to this method.

5.2 Standardize the barium perchlorate solution with 25 ml of standard sulfuric acid, to which 100 ml of 100 percent isopropanol has been added.

## 6. CALCULATIONS

NOTE: Carry out calculations retaining at least one extra decimal figure beyond that of the acquired data. Round off figures after final calculation.

### 6.1 Nomenclature.

$A_n$	=	Cross-sectional area of nozzle, $m^2$ ( $ft^2$ ).
$B_{ws}$	=	Water vapor in the gas stream, proportion by volume.
$C_{H_2SO_4}$	=	Sulfuric acid (including $SO_3$ ) concentration, g/dscm (lb/dscf).
$C_{SO_2}$	=	Sulfur dioxide concentration, g/dscm (lb/dscf).
$I$	=	Percent of isokinetic sampling.
$N$	=	Normality of barium perchlorate titrant, g-equivalents/liter.
$P_{bar}$	=	Barometric pressure at the sampling site, mm Hg (in. Hg).
$P_s$	=	Absolute stack gas pressure, mm Hg (in. Hg).
$P_{std}$	=	Standard absolute pressure, 760 mm Hg (29.92 in. Hg).
$T_m$	=	Average absolute dry gas meter temperature, (see Figure 8-2), $^{\circ}K$ ( $^{\circ}R$ ).
$T_s$	=	Average absolute stack gas temperature, (see Figure 8-2), $^{\circ}K$ ( $^{\circ}R$ ).
$T_{std}$	=	Standard absolute temperature, 293 $^{\circ}K$ (528 $^{\circ}R$ ).
$V_a$	=	Volume of sample aliquot titrated, 100 ml for $H_2SO_4$ and 10 ml for $SO_2$ .
$V_{ic}$	=	Total volume of liquid collected in impingers and silica gel, ml.
$V_m$	=	Volume of gas sample as measured by dry gas meter, dcm (dcf).
$V_{m(std)}$	=	Volume of gas sample measured by the dry gas meter corrected to standard conditions, dscm (dscf).
$v_s$	=	Average stack gas velocity, calculated by method 2, equation 2-9, using data obtained from method 8, m/sec (ft/sec).

$V_{\text{soln}}$	=	Total volume of solution in which the $\text{H}_2\text{SO}_4$ or $\text{SO}_2$ sample is contained, 250 ml or 1000 ml, respectively.
$V_t$	=	Volume of barium standard solution titrant used for the sample, ml.
$V_{\text{cb}}$	=	Volume of barium standard solution titrant used for the blank, ml.
$Y$	=	Dry gas meter calibration factor.
$\Delta H$	=	Average pressure drop across orifice meter, mm Hg (in. Hg).
$\theta$	=	Total sampling time, min.
13.6	=	Specific gravity of Mercury.
60	=	sec/min.
100	=	Conversion to percent.

**6.2 Average Dry Gas Meter Temperature and Average Orifice Pressure Drop.** See data sheet (Figure 8-2).

**6.3 Dry Gas Volume.** Correct the sample volume measured by the dry gas meter to standard conditions (20°C and 760 mm Hg or 68°F and 29.92 in. Hg) by using Equation 8-1.

$$V_{m(\text{std})} = V_m Y \left( \frac{T_{\text{std}}}{T_m} \right) \frac{P_{\text{bar}} + \left( \frac{\Delta H}{13.6} \right)}{P_{\text{std}}}$$

$$= K_1 V_m Y \frac{P_{\text{bar}} + \left( \frac{\Delta H}{13.6} \right)}{T_m}$$

Eq. 8-1

Where:

$K_1$	=	0.3858 °K/mm Hg for metric units.
	=	17.64 °R/in. Hg for English units.

**Note:** If the leak rate observed during any mandatory leak-checks exceeds the specified acceptable rate, the tester shall either correct the value of  $V_m$  in Equation 8-1 (as described in Section 6.3 of Method 5), or shall invalidate the test run.

**6.4 Volume of Water Vapor and Moisture Content.** Calculate the volume of water vapor using Equation 5-2 of Method 5; the weight of water collected in the impingers and silica gel can be converted directly to milliliters (the specific gravity of water is 1 g/ml). Calculate the moisture content of the stack gas, using Equation 5-3 of Method 5. The Note in Section 6.5 of Method 5 also applies to this method. Note that if the effluent gas stream can be considered dry, the volume of water vapor and moisture content need not be calculated.

### 6.5 Sulfuric Acid Mist (Including SO<sub>3</sub>) Concentration.

$$C_{\text{H}_2\text{SO}_4} = K_2 \frac{N(V_t - V_{tb}) \left( \frac{V_{\text{soln}}}{V_a} \right)}{V_{m(\text{std})}} \quad \text{Eq. 8-2}$$

Where:

$$\begin{aligned} K_2 &= 0.04904 \text{ g/milliequivalent for metric units,} \\ &= 1.081 \times 10^{-4} \text{ lb/meq for English units.} \end{aligned}$$

### 6.6 Sulfur Dioxide Concentration.

$$C_{\text{SO}_2} = K_3 \frac{N(V_t - V_{tb}) \left( \frac{V_{\text{soln}}}{V_a} \right)}{V_{m(\text{std})}} \quad \text{Eq. 8-3}$$

Where:

$$\begin{aligned} K_3 &= 0.03203 \text{ g/meq for metric units,} \\ &= 7.061 \times 10^{-5} \text{ lb/meq for English units.} \end{aligned}$$

### 6.7 Isokinetic Variation.

#### 6.7.1 Calculation from raw data.

$$I = \frac{100 T_s \left( K_4 V_{lc} + \left( \frac{V_m Y}{T_m} \right) \left( P_{\text{bar}} + \frac{\Delta H}{13.6} \right) \right)}{60 \theta v_s P_s A_n} \quad \text{Eq. 8-4}$$

Where:

$$\begin{aligned} K_4 &= 0.003464 \text{ mm Hg- m}^3/\text{ml-}^\circ\text{K for metric units.} \\ &= 0.002676 \text{ in. Hg-ft}^3/\text{ml-}^\circ\text{R for English units.} \end{aligned}$$

#### 6.7.2 Calculation from intermediate values.

$$\begin{aligned} I &= \frac{T_s V_{m(\text{std})} P_{\text{std}} 100}{T_{\text{std}} v_s \theta A_n P_s 60 (1 - B_{ws})} \\ &= K_5 \frac{T_s V_{m(\text{std})}}{P_s v_s A_n \theta (1 - B_{ws})} \end{aligned} \quad \text{Eq. 8-5}$$

Where:

$$\begin{aligned} K_5 &= 4.320 \text{ for metric units.} \\ &= 0.09450 \text{ for English units.} \end{aligned}$$

**6.8 Acceptable Results.** If 90 percent  $< I < 110$  percent, the results are acceptable. If the results are low in comparison to the standards and  $I$  is beyond the acceptable range, the Administrator may opt to accept the results. Use Citation 4 in the Bibliography of Method 5 to make judgements. Otherwise, reject the results and repeat the test.

**6.9 Stack Gas Velocity and Volumetric Flow Rate.** Calculate the average stack gas velocity and volumetric flow rate, if needed, using data obtained in this method and equations in Sections 5.2 and 5.3 of Method 2.

**6.10 Relative Error (RE) for QA Audit Samples.** Same as in Method 6, Section 6.4.

#### BIBLIOGRAPHY

1. Atmospheric Emissions from Sulfuric Acid Manufacturing Processes. U.S. DHEW, PHS, Division of Air Pollution. Public Health Service Publication No. 999-AP-13. Cincinnati, OH. 1965.
2. Corbett, P. F. The Determination of  $SO_2$  and  $SO_3$  in Flue Gases. Journal of the Institute of Fuel. 24:237-243. 1961.
3. Martin, Robert M. Construction Details of Isokinetic Source Sampling Equipment. Environmental Protection Agency. Research Triangle Park, NC. Air Pollution Control Office Publication No. APTD-0581. April, 1971.
4. Patton, W. A. and J. A. Brink, Jr. New Equipment and Techniques for Sampling Chemical Process Gases. Journal of Air Pollution Control Association. 13:162. 1963.
5. Rom, J. J. Maintenance, Calibration, and Operation of Isokinetic Source Sampling Equipment. Office of Air Programs, Environmental Protection Agency. Research Triangle Park, NC. APTD-0576. March, 1972.
6. Hamil, H. F. and D. E. Camann. Collaborative Study of Method for Determination of Sulfur Dioxide Emissions from Stationary Sources (Fossil Fuel-Fired Steam Generators). Environmental Protection Agency. Research Triangle Park, NC. EPA-650/4-74-024. December, 1973.
7. Annual Book of ASTM Standards. Part 31; Water, Atmospheric Analysis. pp. 40-42. American Society for Testing and Materials. Philadelphia, PA. 1974.

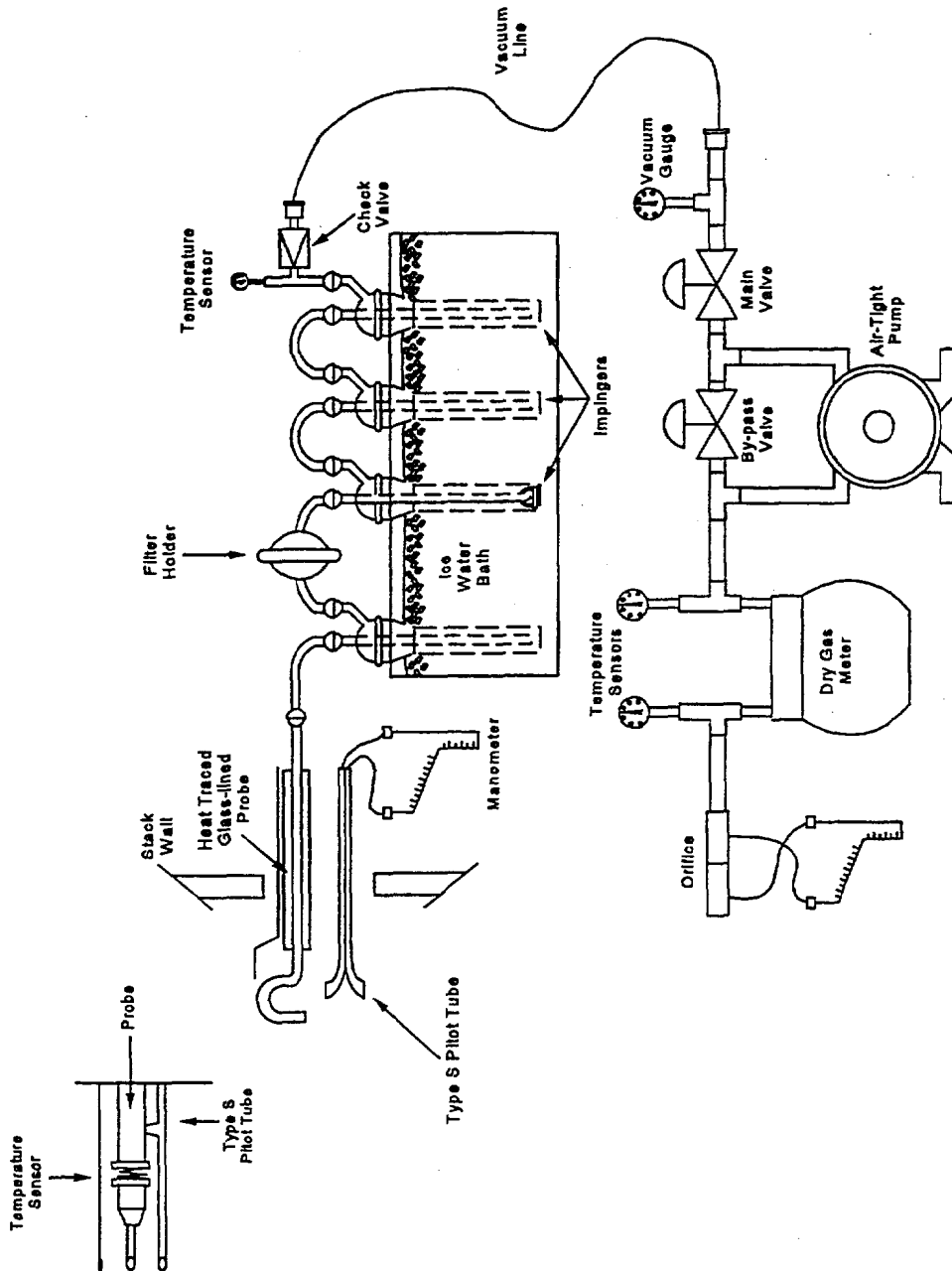

Figure 8-1. Sulfuric Acid Mist Sampling Train.

